



Dual Channel Temperature Sensor and Overtemperature Alarm

ADT7482

FEATURES

- 1 local and 2 remote temperature sensors
- 0.25°C resolution/1°C accuracy on remote channels
- 1°C resolution/1°C accuracy on local channel
- Automatically cancels up to 1.5 kΩ (typ) of resistance in series with the remote sensors
- Extended, switchable temperature measurement range 0°C to +127°C (default) or -55°C to +150°C
- 2-wire SMBus serial interface with SMBus alert support
- Programmable overtemperature/undertemperature limits
- Offset registers for system calibration
- Up to 2 overtemperature fail-safe THERM outputs
- Small, 10-lead MSOP package
- 240 µA operating current, 5 µA standby current

APPLICATIONS

- Desktop and notebook computers
- Industrial controllers
- Smart batteries
- Automotive
- Embedded systems
- Burn-in applications
- Instrumentation

GENERAL DESCRIPTION

The ADT7482¹ is a three-channel digital thermometer and undertemperature/overtemperature alarm for PCs and thermal management systems. It can measure the temperature in two remote locations, such as in the remote thermal diode in a CPU or GPU, or using a discrete diode connected transistor. This device also measures its own ambient temperature.

One feature of the ADT7482 is series resistance cancellation where up to 1.5 kΩ (typical) of resistance in series with each of the temperature monitoring diodes can be automatically cancelled from the temperature result, allowing noise filtering. The temperature of the remote thermal diodes and ambient temperature can be measured accurate to ±1°C. The temperature measurement range, which defaults to 0°C to 127°C, can be switched to a wider measurement range of from -55°C to +150°C.

The ADT7482 communicates over a 2-wire serial interface compatible with system management bus (SMBus) standards. The default address of the ADT7482 is 0x4C. An ALERT output signal when the on-chip or remote temperature is outside the programmed limits. The THERM output is a comparator output that allows on/off control of a cooling fan. The ALERT output can be reconfigured as a second THERM output if required.

¹ Protected by U.S. Patents 5,195,827, 5,867,012, 5,982,221, 6,097,239, 6,133,753, 6,169,442, 7,010,440, other patents pending.

FUNCTIONAL BLOCK DIAGRAM

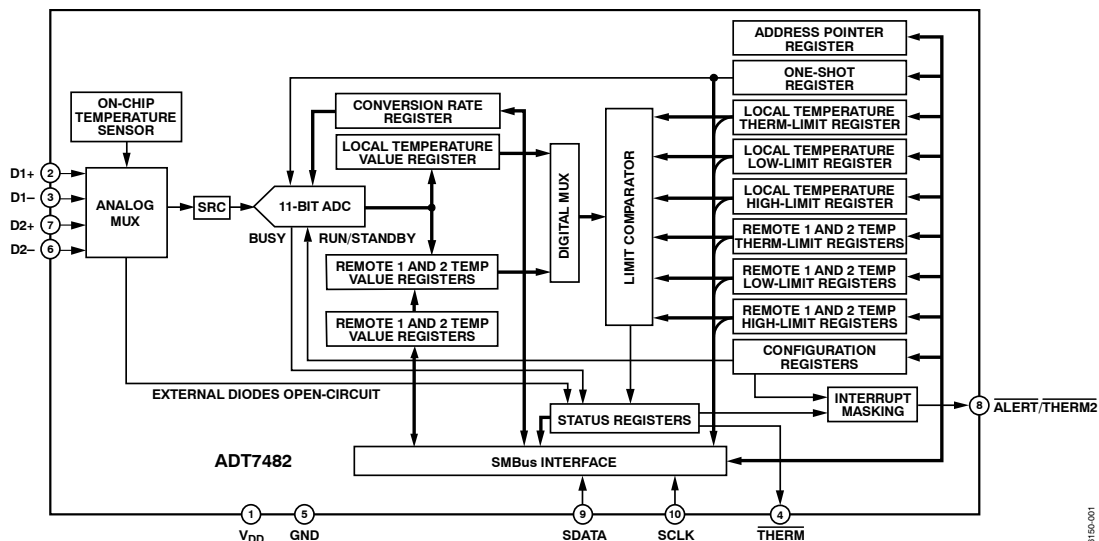

Figure 1.

ADT7482

TABLE OF CONTENTS

Features.....	1	Temperature Value Registers.....	12
Applications.....	1	Conversion Rate Register.....	13
General Description.....	1	Limit Registers.....	13
Functional Block Diagram.....	1	Status Registers.....	14
Revision History.....	2	Offset Register.....	14
Specifications.....	2	One-Shot Register.....	15
Timing Specifications.....	4	Consecutive ALERT Register.....	15
Absolute Maximum Ratings.....	5	Serial Bus Interface.....	17
Thermal Resistance.....	5	Addressing the Device.....	17
ESD Caution.....	5	ALERT Output.....	19
Pin Configuration and Function Descriptions.....	6	Low Power Standby Mode.....	19
Typical Performance Characteristics.....	7	Sensor Fault Detection.....	19
Theory of Operation.....	9	Interrupt System.....	19
Series Resistance Cancellation.....	9	Applications Information.....	22
Temperature Measurement Method.....	9	Noise Filtering.....	22
Temperature Measurement Results.....	10	Factors Affecting Diode Accuracy.....	22
Temperature Measurement Range.....	10	Thermal Inertia and Self-Heating.....	22
Temperature Data Format.....	11	Layout Considerations.....	23
Registers.....	12	Application Circuit.....	23
Address Pointer Register.....	12	Outline Dimensions.....	24
Configuration Registers.....	12	Ordering Guide.....	24

REVISION HISTORY

02/08—Rev 1: Conversion to ON Semiconductor

06/06—Revision 0: Initial Version

SPECIFICATIONS

$T_A = -40^{\circ}\text{C}$ to $+120^{\circ}\text{C}$, $V_{DD} = 3\text{ V}$ to 3.6 V , unless otherwise noted.

Table 1.

Parameter	Min	Typ	Max	Unit	Test Conditions
POWER SUPPLY					
Supply Voltage, V_{DD}	3.0	3.30	3.6	V	
Average Operating Supply Current, I_{DD}		240	350	μA	0.0625 conversions/sec rate ¹
		5	30	μA	Standby mode
Undervoltage Lockout Threshold		2.55		V	V_{DD} input, disables ADC, rising edge
Power-On Reset Threshold	1		2.5	V	
TEMPERATURE-TO-DIGITAL CONVERTER					
Local Sensor Accuracy			± 1	$^{\circ}\text{C}$	$0^{\circ}\text{C} \leq T_A \leq +70^{\circ}\text{C}$
			± 1.5	$^{\circ}\text{C}$	$0^{\circ}\text{C} \leq T_A \leq +85^{\circ}\text{C}$
			± 2.5	$^{\circ}\text{C}$	$-40^{\circ}\text{C} \leq T_A \leq +100^{\circ}\text{C}$
Resolution		1		$^{\circ}\text{C}$	
Remote Diode Sensor Accuracy			± 1	$^{\circ}\text{C}$	$0^{\circ}\text{C} \leq T_A \leq +70^{\circ}\text{C}$, $-55^{\circ}\text{C} \leq T_D^2 \leq +150^{\circ}\text{C}$
			± 1.5	$^{\circ}\text{C}$	$0^{\circ}\text{C} \leq T_A \leq +85^{\circ}\text{C}$, $-55^{\circ}\text{C} \leq T_D^2 \leq +150^{\circ}\text{C}$
			± 2.5	$^{\circ}\text{C}$	$-40^{\circ}\text{C} \leq T_A \leq +100^{\circ}\text{C}$, $-55^{\circ}\text{C} \leq T_D^2 \leq +150^{\circ}\text{C}$
Resolution		0.25		$^{\circ}\text{C}$	
Remote Sensor Source Current		220		μA	High level ³
		82		μA	Mid level ³
		13.5		μA	Low level ²
Maximum Series Resistance Cancelled		1.5		Ω	Resistance split evenly on D+ and D- lines
Conversion Time		71	9	ns	From stop bit to conversion complete (all channels) one-shot mode with averaging switched on
		11.5	15	ms	One-shot mode with averaging off (that is, conversion rate = 16, 32, or 64 conversions per second)
OPEN-DRAIN DIGITAL OUTPUTS (THERM, ALERT/THERM2)					
Output Low Voltage, V_{OL}			0.4	V	$I_{OUT} = -6.0\text{ mA}$
High Level Output Leakage Current, I_{OH}		0.1	1	μA	$V_{OUT} = V_{DD}$
SMBus INTERFACE^{3,4}					
Logic Input High Voltage, V_{IH} SCLK, SDATA	2.1			V	
Logic Input Low Voltage, V_{IL} SCLK, SDATA			0.8	V	
Hysteresis		500		mV	
SDA Output Low Voltage, V_{OL}			0.4	V	$I_{OUT} = -6.0\text{ mA}$
Logic Input Current, I_{IH} , I_{IL}	-1		+1	μA	
SMBus Input Capacitance, SCLK, SDATA		5		pF	
SMBus Clock Frequency			400	kHz	
SMBus Timeout ⁵		25	64	ms	User programmable
SCLK Falling Edge to SDATA Valid Time			1	μs	Master clocking in data

¹ See Table 11 for conversion rates.

² Guaranteed by characterization, but not production tested.

³ Guaranteed by design, but not production tested.

⁴ See the Timing Specifications section for more information.

⁵ Disabled by default. For details on enabling the SMBus, see the Serial Bus Interface section.

ADT7482

TIMING SPECIFICATIONS

Table 2. SMBus Timing Specifications¹

Parameter	Limit at T _{MIN} , T _{MAX}	Unit	Description
f _{SCLK}	400	kHz max	
t _{LOW}	1.3	μs min	Clock low period, between 10% points.
t _{HIGH}	0.6	μs min	Clock high period, between 90% points.
t _R	300	ns max	Clock/data rise time.
t _F	300	ns max	Clock/data fall time.
t _{SU;STA}	600	ns min	Start condition setup time.
t _{HD;STA} ²	600	ns min	Start condition hold time.
t _{SU;DAT} ³	100	ns min	Data setup time.
t _{SU;STO} ⁴	600	ns min	Stop condition setup time.
t _{BUF}	1.3	μs min	Bus free time between stop and start conditions.

¹ Guaranteed by design, but not production tested.

² Time from 10% of SDATA to 90% of SCLK.

³ Time for 10% or 90% of SDATA to 10% of SCLK.

⁴ Time for 90% of SCLK to 10% of SDATA.

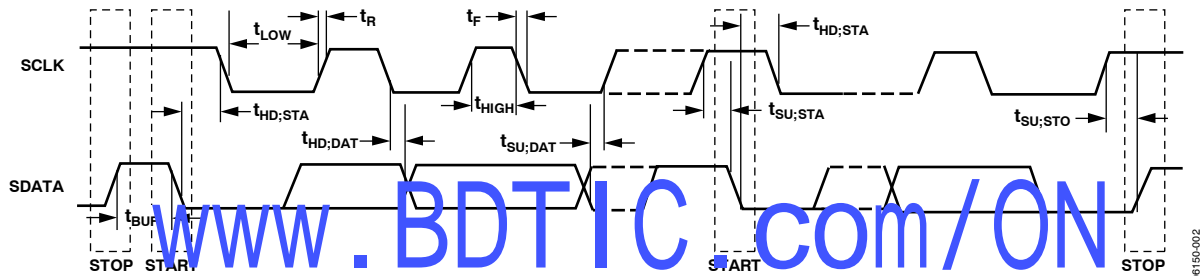

Figure 2. Serial Bus Timing

06150-002

ABSOLUTE MAXIMUM RATINGS

Table 3.

Parameter	Rating
Positive Supply Voltage (V_{DD}) to GND	-0.3 V to +3.6 V
D+	-0.3 V to $V_{DD} + 0.3$ V
D- to GND	-0.3 V to +0.6 V
SCLK, SDATA, ALERT, THERM	-0.3 V to +3.6 V
Input Current, SDATA, THERM	-1 mA, to +50 mA
Input Current, D-	± 1 mA
ESD Rating, All Pins (Human Body Model)	2000 V
Maximum Junction Temperature (T_J Max)	150°C
Storage Temperature Range	-65°C to +150°C
IR Reflow Peak Temperature	220°C
IR Reflow Peak Temperature Pb-Free	260°C
Lead Temperature (Soldering 10 sec)	300°C

Stresses above those listed under Absolute Maximum Ratings may cause permanent damage to the device. This is a stress rating only; functional operation of the device at these or any other conditions above those indicated in the operational section of this specification is not implied. Exposure to absolute maximum rating conditions for extended periods may affect device reliability.

THERMAL RESISTANCE

θ_{JA} is specified for the worst-case conditions, that is, a device soldered in a circuit board for surface-mount packages.

Table 4. Thermal Resistance

Package Type	θ_{JA}	θ_{JC}	Unit
10-Lead MSOP	142	43.7	°C/W

ESD CAUTION

ESD (electrostatic discharge) sensitive device. Electrostatic charges as high as 4000 V readily accumulate on the human body and test equipment and can discharge without detection. Although this product features proprietary ESD protection circuitry, permanent damage may occur on devices subjected to high energy electrostatic discharges. Therefore, proper ESD precautions are recommended to avoid performance degradation or loss of functionality.



www.BDTIC.com/ON

ADT7482

PIN CONFIGURATION AND FUNCTION DESCRIPTIONS

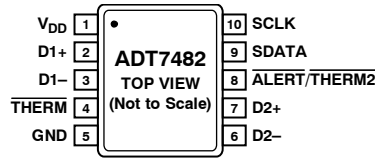

Table 5. Pin Function Descriptions

Pin No.	Mnemonic	Description
1	V _{DD}	Positive Supply, 3 V to 3.6 V.
2	D1+	Positive Connection to the First Remote (Remote 1) Temperature Sensor.
3	D1-	Negative Connection to the First Remote (Remote 1) Temperature Sensor.
4	THERM	Open-Drain Output. This pin can be used to turn a fan on/off or throttle a CPU clock in the event of an overtemperature condition. Requires pull-up resistor.
5	GND	Supply Ground Connection.
6	D2-	Negative Connection to the Second Remote (Remote 2) Temperature Sensor.
7	D2+	Positive Connection to the Second Remote (Remote 2) Temperature Sensor.
8	ALERT /THERM2	Open-Drain Logic Output. This pin is used as interrupt or SMBus alert. May also be configured as a second THERM output. Requires pull-up resistor.
9	SDATA	Logic Input/Output, SMBus Serial Data. Open-drain output. Requires pull-up resistor.
10	SCLK	Logic Input, SMBus Serial Clock. Requires pull-up resistor.

www.BDTIC.com/ON

TYPICAL PERFORMANCE CHARACTERISTICS

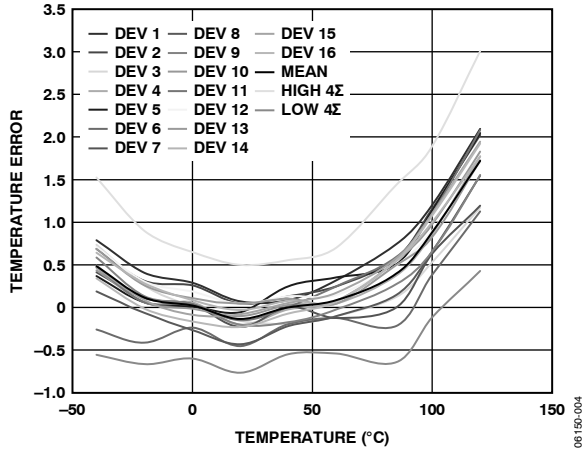

Figure 4. Local Temperature Error vs. Temperature

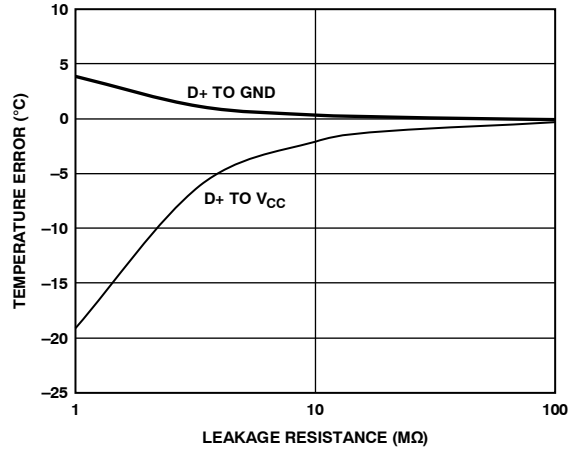

Figure 7. Temperature Error vs. D+/D- Leakage Resistance

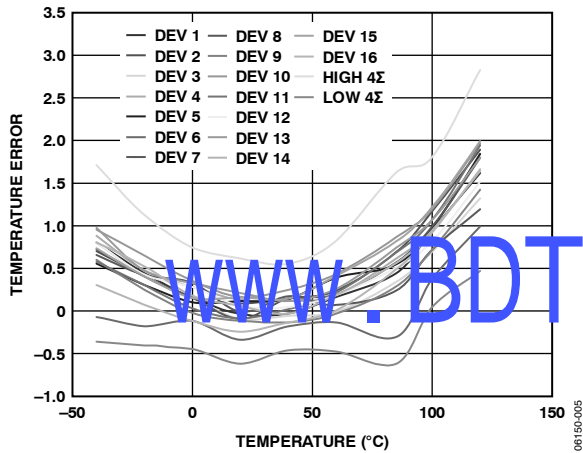

Figure 5. Remote 1 Temperature Error vs. Temperature

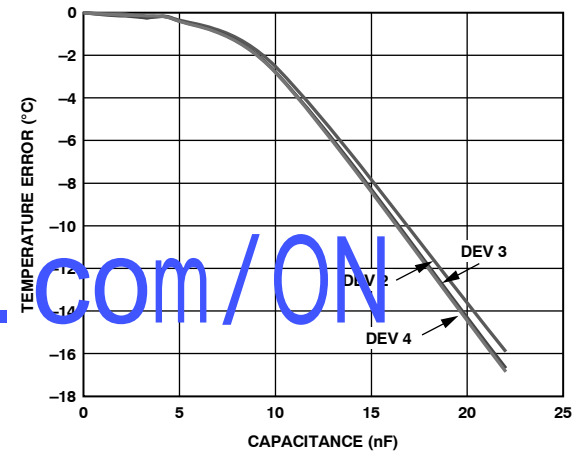

Figure 8. Temperature Error vs. D+/D- Capacitance

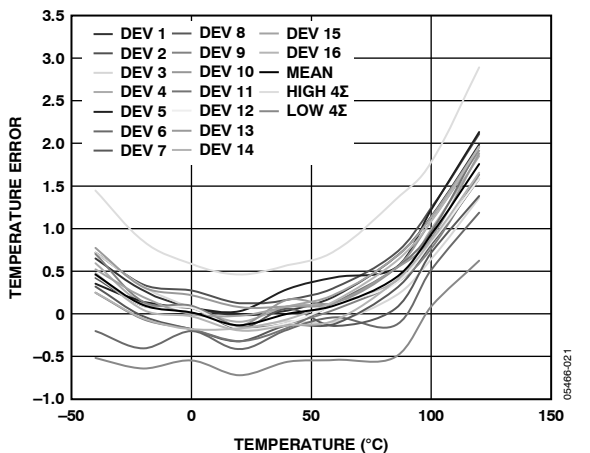

Figure 6. Remote 2 Temperature Error vs. Temperature

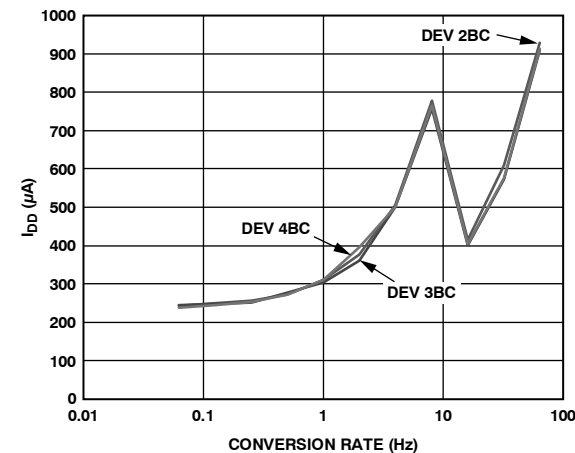

Figure 9. Operating Supply Current vs. Conversion Rate

www.BDTIC.com/ON

ADT7482

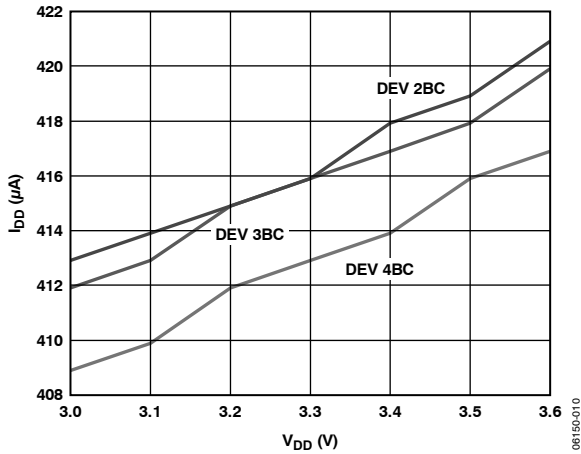

Figure 10. Operating Supply Current vs. Voltage

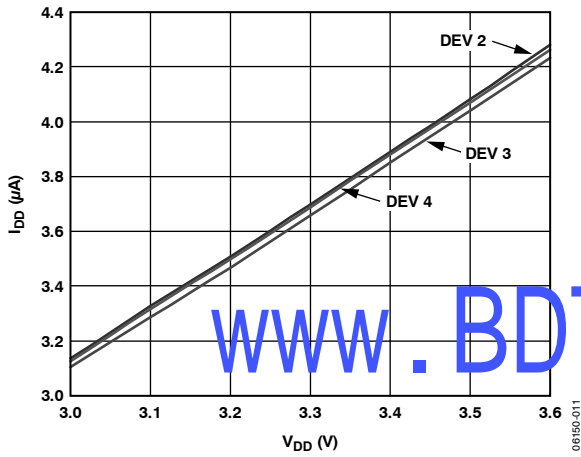

Figure 11. Standby Supply Current vs. Voltage

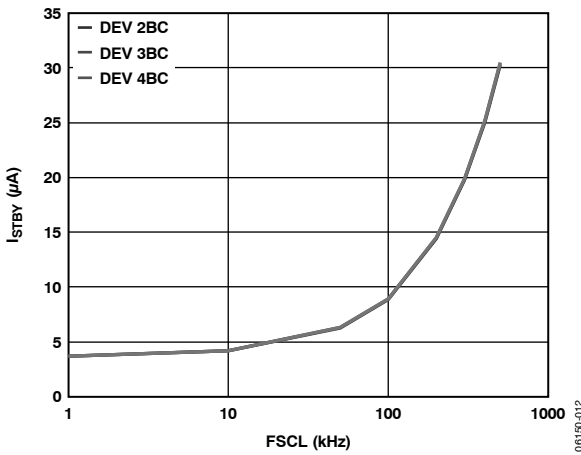

Figure 12. Standby Supply Current vs. Clock Frequency

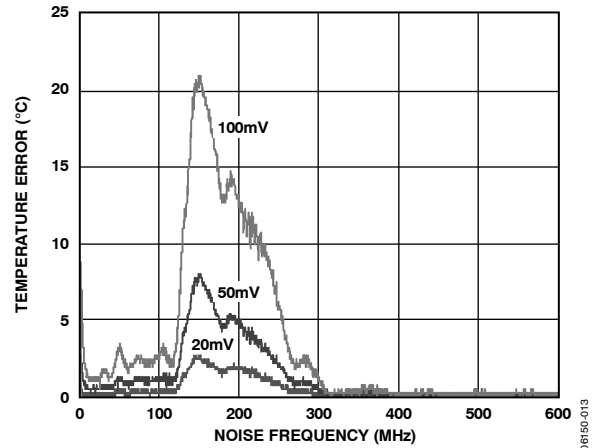

Figure 13. Temperature Error vs. Common Mode Noise Frequency

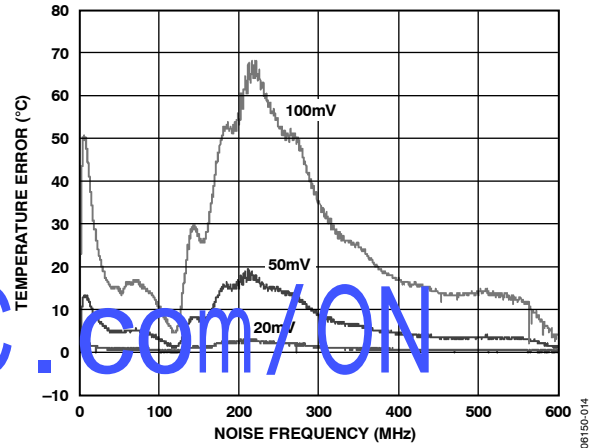

Figure 14. Temperature Error vs. Differential Mode Noise Frequency

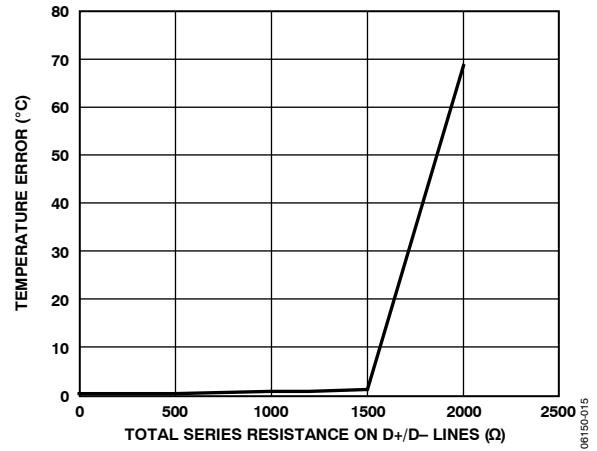

Figure 15. Temperature Error vs. Series Resistance

THEORY OF OPERATION

The ADT7482 is a local and 2× remote temperature sensor and overtemperature/undertemperature alarm. When the ADT7482 is operating normally, the on-board ADC operates in a free-running mode. The analog input multiplexer alternately selects either the on-chip temperature sensor to measure its local temperature or either of the remote temperature sensors. The ADC digitizes these signals and the results are stored in the local, Remote 1, and Remote 2 temperature value registers.

The local and remote measurement results are compared with the corresponding high, low, and THERM temperature limits, stored in on-chip registers. Out-of-limit comparisons generate flags that are stored in the status register. A result that exceeds the high temperature limit, the low temperature limit, or a remote diode open circuit causes the ALERT output to assert low. Exceeding THERM temperature limits causes the THERM output to assert low. The ALERT output can be reprogrammed as a second THERM output.

The limit registers can be programmed, and the device controlled and configured, via the serial SMBus. The contents of any register can also be read back via the SMBus.

Control and configuration functions consist of switching the device between normal operation and standby mode, selecting the temperature measurement scale, masking or enabling the ALERT output, switching Pin 8 between ALERT and THERM2, and selecting the conversion rate.

SERIES RESISTANCE CANCELLATION

Parasitic resistance to the D+ and D− inputs to the ADT7482, seen in series with the remote diode, is caused by a variety of factors, including PCB track resistance and track length. This series resistance appears as a temperature offset in the remote sensor temperature measurement. This error typically causes a 0.5°C offset per ohm of parasitic resistance in series with the remote diode.

The ADT7482 automatically cancels out the effect of this series resistance on the temperature reading, providing a more accurate result, without the need for user characterization of this resistance. The ADT7482 is designed to automatically cancel typically up to 1.5 kΩ of resistance. By using an advanced temperature measurement method, this is transparent to the user. This feature allows resistances to be added to the sensor path to produce a filter, allowing the part to be used in noisy environments. See the Noise Filtering section for more details.

TEMPERATURE MEASUREMENT METHOD

A simple method of measuring temperature is to exploit the negative temperature coefficient of a diode, measuring the base-emitter voltage (V_{BE}) of a transistor operated at constant current. However, this technique requires calibration to null out the effect of the absolute value of V_{BE} , which varies from device to device.

The technique used in the ADT7482 is to measure the change in V_{BE} when the device is operated at three different currents. Previous devices have used only two operating currents. The use of a third current allows automatic cancellation of resistances in series with the external temperature sensor.

Figure 16 shows the input signal conditioning used to measure the output of an external temperature sensor. This figure shows the external sensor as a substrate transistor, but it could equally be a discrete transistor. If a discrete transistor is used, the collector is not grounded and should be linked to the base. To prevent ground noise from interfering with the measurement, the more negative terminal of the sensor is not referenced to ground, but is biased above ground by an internal diode at the D− input. Capacitor C1 can be added as a noise filter (a recommended maximum value of 1000 pF). However, a better option in noisy environments is to add a filter, as described in the Noise Filtering section. See the Layout Considerations section for more information.

To measure ΔV_{BE} , the operating current through the sensor is switched among three related currents. Shown in Figure 16, $N1 \times I$ and $N2 \times I$ are different multiples of the current, I . The currents through the temperature diode are switched between I and $N1 \times I$, giving ΔV_{BE1} , and then between I and $N2 \times I$, giving ΔV_{BE2} . The temperature can then be calculated using the two ΔV_{BE} measurements. This method can also be shown to cancel the effect of any series resistance on the temperature measurement.

The resulting ΔV_{BE} waveforms are passed through a 65 kHz low-pass filter to remove noise and then to a chopper-stabilized amplifier. This amplifies and rectifies the waveform to produce a dc voltage proportional to ΔV_{BE} . The ADC digitizes this voltage and a temperature measurement is produced. To reduce the effects of noise, digital filtering is performed by averaging the results of 16 measurement cycles for low conversion rates. At rates of 16, 32, and 64 conversions/second, no digital averaging takes place.

Signal conditioning and measurement of the internal temperature sensor are performed in the same manner.

ADT7482

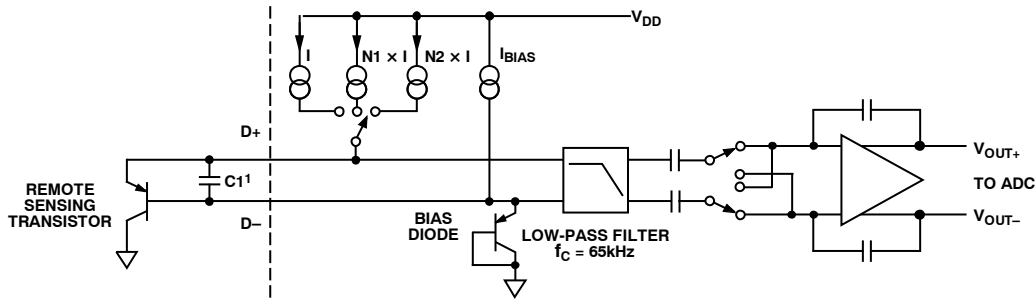

¹ CAPACITOR C1 IS OPTIONAL. IT SHOULD ONLY BE USED IN NOISY ENVIRONMENTS.

Figure 16. Input Signal Conditioning

09150016

TEMPERATURE MEASUREMENT RESULTS

The results of the local and remote temperature measurements are stored in the local and remote temperature value registers and are compared with limits programmed into the local and remote high and low limit registers.

The local temperature measurement is an 8-bit measurement with 1°C resolution. The remote temperature measurements are 10-bit measurements, with the 8 MSBs stored in one register and the 2 LSBs stored in another register. Table 6 is a list of the temperature measurement registers.

Table 6. Register Address for the Temperature Values

Temperature Channel	Register Address, MSBs	Register Address, LSBs
Local	0x00	N/A
Remote 1	0x01	0x10 (2 MSBs)
Remote 2	0x30	0x33 (2 MSBs)

Set Bit 3 of the Configuration 1 register to 1, to read the Remote 2 temperature values from the following register addresses:

- Remote 2, MSBs = 0x01
- Remote 2, LSBs = 0x10

The above is true only when Bit 3 of the Configuration 1 register is set. To read the Remote 1 temperatures, switch this bit back to 0.

Only the two MSBs in the remote temperature low byte are used. This gives the remote temperature measurement a resolution of 0.25°C. Table 7 shows the data format for the remote temperature low byte.

Table 7. Extended Temperature Resolution (Remote Temperature Low Byte)

Extended Resolution	Remote Temperature Low Byte
0.00°C	0 000 0000
0.25°C	0 100 0000
0.50°C	1 000 0000
0.75°C	1 100 0000

When reading the full remote temperature value, both the high and low byte, the two registers should be read LSB first and then MSB. Reading the LSB causes the MSB to be locked until it is read. This guarantees that the two values are read as a result of the same temperature measurement.

TEMPERATURE MEASUREMENT RANGE

The temperature measurement range for both local and remote measurements is, by default, 0°C to +127°C. However, the ADT7482 can be operated using an extended temperature range. It can measure the full temperature range of a remote thermal diode, from -55°C to +150°C. Switch between these two temperature ranges by setting or clearing Bit 2 in the Configuration 1 register. A valid result is available in the next measurement cycle after changing the temperature range.

In extended temperature mode, the upper and lower temperature measured by the ADT7482 is limited by the remote diode selection. The temperature registers themselves can have values from -64°C to +191°C. However, most temperature-sensing diodes have a maximum temperature range of -55°C to +150°C.

Note that while both local and remote temperature measurements can be made while the part is in extended temperature mode, the ADT7482 itself should not be exposed to temperatures greater than those specified in the Absolute Maximum Ratings section. Further, the device is only guaranteed to operate as specified at ambient temperatures from -40°C to +120°C.

TEMPERATURE DATA FORMAT

The ADT7482 has two temperature data formats. When the temperature measurement range is from 0°C to 127°C (default), the temperature data format for both local and remote temperature results is binary.

When the measurement range is in extended mode, an offset binary data format is used for both local and remote results. Temperature values in the offset binary data format are offset by +64. Examples of temperatures in both data formats are shown in **Table 8**.

Switching between measurement ranges can be done at any time. Switching the range also switches the data format. The next temperature result following the switching is reported back to the register in the new format. However, the contents of the limit registers do not change. Ensure that when the data format changes, the limit registers are reprogrammed as necessary. For more information, refer to the Limit Registers section.

Table 8. Temperature Data Format (Local and Remote Temperature High Byte)

Temperature	Binary	Offset Binary ¹
-55°C	0 000 0000 ²	0 000 1001
0°C	0 000 0000	0 100 0000
+1°C	0 000 0001	0 100 0001
+10°C	0 000 1010	0 100 1010
+25°C	0 001 1001	0 101 1001
+50°C	0 011 0010	0 111 0010
+75°C	0 100 1011	1 000 1011
+100°C	0 110 0100	1 010 0100
+125°C	0 111 1101	1 011 1101
+127°C	0 111 1111	1 011 1111
+150°C	0 111 1111 ³	1 101 0110

¹ Offset binary scale temperature values are offset by 64.

² Binary scale temperature measurement returns 0 for temperature < 0°C.

³ Binary scale temperature measurement returns 127 for temperature > 127°C.

ADT7482

REGISTERS

The registers in the ADT7482 are 8-bits wide. These registers are used to store the results of remote and local temperature measurements and high and low temperature limits and to configure and control the device. A description of these registers follows.

ADDRESS POINTER REGISTER

The address pointer register itself does not have, or require, an address, as the first byte of every write operation is automatically written to this register. The data in this first byte always contains the address of another register on the ADT7482, which is stored in the address pointer register. It is to this register address that the second byte of a write operation is written to or to which a subsequent read operation is performed.

The power-on default value of the address pointer register is 0x00. Therefore, if a read operation is performed immediately after power-on, without first writing to the address pointer, the value of the local temperature is returned, since its register address is 0x00.

CONFIGURATION REGISTERS

There are two configuration registers used to control the operation of the ADT7482. Configuration 1 register is at Address 0x03 for reads and Address 0x09 for writes. See Table 9 for details regarding the operation of this register. Configuration 2 Register is at Address 0x24 for both reads and writes. Setting Bit

7 of this register locks all lockable registers. The affected registers can only be modified if the ADT7482 is powered down and powered up again. See Table 16 for a list of the registers affected by the lock bit.

TEMPERATURE VALUE REGISTERS

The ADT7482 has five registers to store the results of local and remote temperature measurements. These registers can only be written to by the ADC and can be read over the SMBus.

- The local temperature value register is at Address 0x00.
- The Remote 1 temperature value high byte register is at Address 0x01; the Remote 1 low byte register is at Address 0x10.
- The Remote 2 temperature value high byte register is at Address 0x30; the Remote 2 low byte register is at Address 0x33.
- The Remote 2 temperature values can be read from Addresses 0x01 for the high byte and Address 0x10 for the low byte if Bit 3 of Configuration Register 1 is set to 1.
- To read the Remote 1 temperature values, set Bit 3 of Configuration Register 1 to 0.
- The power-on default for all five registers is 0x00.

Table 9. Configuration 1 Register (Read Address = 0x03, Write Address = 0x09)

Bit	Mnemonic	Description
7	Mask	Setting this bit to 1 masks all <u>ALERTs</u> on the <u>ALERT</u> pin. Default = 0 = <u>ALERT</u> enabled. This applies only if Pin 8 is configured as <u>ALERT</u> , otherwise it has no effect.
6	Mon/STBY	Setting this bit to 1 places the ADT7482 in standby mode (that is, it suspends all <u>temperature measurements</u> (ADC). The SMBus remains active and values can be written to and read from the registers. <u>THERM</u> and <u>ALERT</u> are also active in standby mode. Changes made to the limit registers in standby mode that effect the <u>THERM</u> or <u>ALERT</u> outputs cause these signals to be updated. Default = 0 = temperature monitoring enabled.
5	AL/TH	This bit selects the function of Pin 8. Default = 0 = <u>ALERT</u> . Setting this bit to 1 configures Pin 8 as <u>THERM2</u> pin.
4	Reserved	Reserved for future use.
3	Remote 1 /Remote 2	Setting this bit to 1 enables Remote 2 values to be read from the Remote 1 registers. Default = 0 = Remote 1 temperature values and limits are read from these registers.
2	Temp Range	Setting this bit to 1 enables the extended temperature measurement range (–50°C to +150°C). Default = 0 = (0°C to +127°C).
1	Mask R1	Setting this bit to 1 masks <u>ALERTs</u> due to the Remote 1 temperature exceeding a programmed limit. Default = 0.
0	Mask R2	Setting this bit to 1 masks <u>ALERTs</u> due to the Remote 2 temperature exceeding a programmed limit. Default = 0.

Table 10. Configuration 2 Register (Read/Write Address = 0x24)

Bit	Mnemonic	Description
7	Lock Bit	Setting this bit to 1 locks all lockable registers to their current values. This prevents settings from being tampered with until the device is powered down. Default = 0.
<6:0>	Res	Reserved for future use.

CONVERSION RATE REGISTER

The conversion rate register is at Address 0x04 for reads and Address 0x0A for writes. The four LSBs of this register are used to program the conversion times from 15.5 ms (Code 0x0A) to 16 seconds (Code 0x00). To program the ADT7482 to perform continuous measurements, set the conversion rate register to 0x0B. For example, a conversion rate of 8 conversions/second means that, beginning at 125 ms intervals, the device performs a conversion on the local and the remote temperature channels. The four MSBs of this register are reserved and should not be written to.

This register can be written to and read back over the SMBus. The default value of this register is 0x07, giving a rate of 8 conversions per second. Use of slower conversion times greatly reduces the device power consumption.

LIMIT REGISTERS

The ADT7482 has three limits for each temperature channel: high, low, and THERM temperature limits for local, Remote 1, and Remote 2 temperature measurements. The remote temperature high and low limits span two registers each, to contain an upper and lower byte for each limit. There is also a THERM hysteresis register. All limit registers can be written to and read back over the SMBus. See Table 16 for limit register addresses and power-on default values.

When Pin 8 is configured as an ALERT output, the high limit registers perform a > comparison while the low limit registers perform a ≤ comparison. For example, if the high limit register is programmed with 80°C, then measuring 81°C results in an out-of-limit condition, setting a flag in the status register. If the low limit register is programmed with 0°C, measuring 0°C or lower results in an out-of-limit condition.

Exceeding either the local or remote THERM limit asserts THERM low. When Pin 8 is configured as THERM2, exceeding either the local or remote high limit asserts THERM2 low. A default hysteresis value of 10°C is provided that applies to both THERM channels. This hysteresis value can be reprogrammed.

It is important to remember that the temperature limits data format is the same as the temperature measurement data format. If the temperature measurement uses the default binary scale, then the temperature limits also use the binary scale. If the temperature measurement scale is switched, however, the temperature limits do not switch automatically.

The limit registers must be reprogrammed to the desired value in the correct data format. For example, if the remote low limit is set at 10°C and the default binary scale is used, the limit register value should be 0000 1010b. If the scale is switched to offset binary, the value in the low temperature limit register should be reprogrammed to be 0100 1010b.

Table 11. Conversion Rate Register (Read Address = 0x04, Write Address = 0x0A)

Bit	Mnemonic	Function																								
7	Reserved	Reserved for future use. Do not write to this bit.																								
6	Reserved	Reserved for future use. Do not write to this bit.																								
5	Reserved	Reserved for future use. Do not write to this bit.																								
4	Reserved	Reserved for future use. Do not write to this bit.																								
<3:0>	Conversion rates	These bits set how often the ADT7482 measures each temperature channel.																								
		<table border="1"> <thead> <tr> <th>Conversions/sec</th> <th>Time (seconds)</th> </tr> </thead> <tbody> <tr> <td>0000 = 0.0625</td> <td>16</td> </tr> <tr> <td>0001 = 0.125</td> <td>8</td> </tr> <tr> <td>0010 = 0.25</td> <td>4</td> </tr> <tr> <td>0011 = 0.5</td> <td>2</td> </tr> <tr> <td>0100 = 1</td> <td>1</td> </tr> <tr> <td>0101 = 2</td> <td>500 m</td> </tr> <tr> <td>0110 = 4</td> <td>250 m</td> </tr> <tr> <td>0111 = 8 = default</td> <td>125 m</td> </tr> <tr> <td>1000 = 16</td> <td>62.5 m</td> </tr> <tr> <td>1001 = 32</td> <td>31.25 m</td> </tr> <tr> <td>1010 = 64</td> <td>15.5 m</td> </tr> </tbody> </table>	Conversions/sec	Time (seconds)	0000 = 0.0625	16	0001 = 0.125	8	0010 = 0.25	4	0011 = 0.5	2	0100 = 1	1	0101 = 2	500 m	0110 = 4	250 m	0111 = 8 = default	125 m	1000 = 16	62.5 m	1001 = 32	31.25 m	1010 = 64	15.5 m
Conversions/sec	Time (seconds)																									
0000 = 0.0625	16																									
0001 = 0.125	8																									
0010 = 0.25	4																									
0011 = 0.5	2																									
0100 = 1	1																									
0101 = 2	500 m																									
0110 = 4	250 m																									
0111 = 8 = default	125 m																									
1000 = 16	62.5 m																									
1001 = 32	31.25 m																									
1010 = 64	15.5 m																									

ADT7482

STATUS REGISTERS

The status registers are read-only registers at Addresses 0x02 (Status Register 1) and Address 0x23 (Status Register 2). They contain status information for the ADT7482.

Table 12. Status Register 1 Bit Assignments

Bit	Name	Function	ALERT
7	BUSY	1 when ADC converting	No
6	LHIGH ¹	1 when local high temperature limit tripped	Yes
5	LLOW ¹	1 when local low temperature limit tripped	Yes
4	R1HIGH ¹	1 when Remote 1 high temperature limit tripped	Yes
3	R1LOW ¹	1 when Remote 1 low temperature limit tripped	Yes
2	D1 OPEN ¹	1 when Remote 1 sensor open circuit	Yes
1	R1THRM1	1 when Remote1 $\overline{\text{THERM}}$ limit tripped	No
0	LTHR1	1 when local $\overline{\text{THERM}}$ limit tripped	No

¹These flags stay high until the status register is read, or they are reset by POR.

Table 13. Status Register 2 Bit Assignments

Bit	Name	Function	ALERT
7	Res	Reserved for future use	No
6	Res	Reserved for future use	No
5	Res	Reserved for future use	No
4	R2HIGH ¹	1 when Remote 2 high temperature limit tripped	Yes
3	R2LOW ¹	1 when Remote 2 low temperature limit tripped	Yes
2	D2 OPEN ¹	1 when Remote 2 sensor open circuit	Yes
1	R2THRM1	1 when Remote2 $\overline{\text{THERM}}$ limit tripped	No
0	ALERT	1 when ALERT condition exists.	No

¹These flags stay high until the status register is read, or they are reset by POR.

The eight flags that can generate an $\overline{\text{ALERT}}$ are NOR'd together. When any flags are high, the $\overline{\text{ALERT}}$ interrupt latch is set and the $\overline{\text{ALERT}}$ output goes low (provided they are not masked out).

Reading the Status 1 register clears the 5 flags, (Bit 6 through Bit 2) in Status Register 1, provided the error conditions that caused the flags to be set have gone away. Reading the Status 2 Register clears the three flags, (Bit 4 through Bit 2) in Status Register 2, provided the error conditions that caused the flags to be set have gone away. A flag bit can only be reset if the corresponding value register contains an in-limit measurement or if the sensor is good.

The $\overline{\text{ALERT}}$ interrupt latch is not reset by reading the status register. It is reset when the $\overline{\text{ALERT}}$ output has been serviced by the master reading the device address, provided the error

condition has gone away and the status register flag bits have been reset.

When Flag 1 and/or Flag 0 of Status Register 1 or Flag 1 of Status Register 2 are set, the $\overline{\text{THERM}}$ output goes low to indicate that the temperature measurements are outside the programmed limits. The $\overline{\text{THERM}}$ output does not need to be reset, unlike the $\overline{\text{ALERT}}$ output. Once the measurements are within the limits, the corresponding status register bits are reset automatically, and the $\overline{\text{THERM}}$ output goes high. To add hysteresis, program Register 0x21. The $\overline{\text{THERM}}$ output is reset only when the temperature falls below the $\overline{\text{THERM}}$ limit minus hysteresis.

When Pin 8 is configured as $\overline{\text{THERM2}}$, only the high temperature limits are relevant. If Flag 6 or Flag 4 of Status Register 1 or Flag 4 of Status Register 2 are set, the $\overline{\text{THERM2}}$ output goes low to indicate that the temperature measurements are outside the programmed limits. Flag 5 and Flag 3 of Status Register 1 and Flag 3 of Status Register 2 have no effect on $\overline{\text{THERM2}}$. The behavior of $\overline{\text{THERM2}}$ is otherwise the same as $\overline{\text{THERM}}$.

Bit 0 of the Status Register 2 is set whenever the ADT7482 $\overline{\text{ALERT}}$ output is asserted low. Read Status Register 2 to determine if the ADT7482 is responsible for the $\overline{\text{ALERT}}$. This bit is reset when the $\overline{\text{ALERT}}$ output is reset. If the $\overline{\text{ALERT}}$ output is masked, then this bit is not set.

OFFSET REGISTER

Offset errors can be introduced into the remote temperature measurement by clock noise or by the thermal diode being located away from the hot spot. To achieve the specified accuracy on this channel, these offsets must be removed.

The offset values are stored as 10-bit, twos complement values.

- The Remote 1 Offset MSBs are stored in Register 0x11 and the LSBs are stored in Register 0x12 (low byte, left justified). The Remote 2 Offset MSBs are stored in Register 0x34 and the LSBs are stored in Register 0x35 (low byte, left justified).
- The Remote 2 Offset can be written to or read from the Remote 1 Offset Registers if Bit 3 of the Configuration 1 register is set to 1. This bit should be set to 0 (default) to read the Remote 1 offset values.

Only the upper 2 bits of the LSB registers are used. The MSB of MSB offset registers is the sign bit. The minimum offset that can be programmed is -128°C , and the maximum is $+127.75^{\circ}\text{C}$. The value in the offset register is added or subtracted to the measured value of the remote temperature.

The offset register powers up with a default value of 0°C and has no effect unless a different value is written to it.

Table 14. Sample Offset Register Codes

Offset Value	0x11/0x34	0x12/0x35
-128°C	1000 0000	00 00 0000
-4°C	1111 1100	00 00 0000
-1°C	1111 1111	00 000000
-0.25°C	1111 1111	11 00 0000
0°C	0000 0000	00 00 0000
+0.25°C	0000 0000	01 00 0000
+1°C	0000 0001	00 00 0000
+4°C	0000 0100	00 00 0000
+127.75°C	0111 1111	11 00 0000

ONE-SHOT REGISTER

The one-shot register initiates a conversion and comparison cycle when the ADT7482 is in standby mode, after which the device returns to standby. Writing to the one-shot register address (0x0F) causes the ADT7482 to perform a conversion and comparison on both the local and the remote temperature channels. This is not a data register as such, and it is the write operation to Address 0x0F that causes the one-shot conversion. The data written to this address is irrelevant and is not stored.

CONSECUTIVE ALERT REGISTER

The value written to this register determines how many out-of-limit measurements must occur before an ALERT is generated. The default value is that one out-of-limit measurement generates an ALERT. The maximum value that can be chosen is 4. This register allows some filtering of the output. This is particularly useful at the fastest three conversion rates, where no averaging takes place. This register address is 0x22. For more information, refer to Table 15.

Table 15. Consecutive ALERT Register Bit

Register Value ¹	Amount of Out-of-Limit Measurements Required
yzax 000x	1
yzax 001x	2
yzax 011x	3
yzax 111x	4

¹ Notes:
y = SMBus SCL timeout bit. Default = 0. See the Serial Bus Interface section for more information.
z = SMBus SDA timeout bit. Default = 0. See the Serial Bus Interface section for more information.
a = Mask Internal ALERTs.
x = Don't care bit.

www.BDTIC.com/ON

ADT7482

Table 16. List of Registers

Read Address (Hex)	Write Address (Hex)	Name	Power-On Default	Comment	Lock
N/A	N/A	Address Pointer	Undefined		No
00	N/A	Local Temperature Value	0000 0000 (0x00)		No
01	N/A	Remote 1 Temperature Value High Byte	0000 0000 (0x00)	Bit 3 Conf. Reg. = 0	No
01	N/A	Remote 2 Temperature Value High Byte	0000 0000 (0x00)	Bit 3 Conf. Reg. = 1	No
02	N/A	Status Register 1	Undefined		No
03	09	Configuration Register 1	0000 0000 (0x00)		Yes
04	0A	Conversion Rate	0000 0111 (0x07)		Yes
05	0B	Local Temperature High Limit	0101 0101 (0x55) (85°C)		Yes
06	0C	Local Temperature Low Limit	0000 0000 (0x00) (0°C)		Yes
07	0D	Remote 1 Temperature High Limit High Byte	0101 0101 (0x55) (85°C)	Bit 3 Conf. Reg. = 0	Yes
07	0D	Remote 2 Temperature High Limit High Byte	0101 0101 (0x55) (85°C)	Bit 3 Conf. Reg. = 1	Yes
08	0E	Remote 1 Temperature Low Limit High Byte	0000 0000 (0x00) (0°C)	Bit 3 Conf. Reg. = 0	Yes
08	0E	Remote 2 Temperature Low Limit High Byte	0000 0000 (0x00) (0°C)	Bit 3 Conf. Reg. = 1	Yes
N/A	0F ¹	One Shot			N/A
10	N/A	Remote 1 Temperature Value Low Byte	0000 0000	Bit 3 Conf. Reg. = 0	No
10	N/A	Remote 2 Temperature Value Low Byte	0000 0000	Bit 3 Conf. Reg. = 1	No
11	11	Remote 1 Temperature Offset High Byte	0000 0000	Bit 3 Conf. Reg. = 0	Yes
11	11	Remote 2 Temperature Offset High Byte	0000 0000	Bit 3 Conf. Reg. = 1	Yes
12	12	Remote 1 Temperature Offset Low Byte	0000 0000	Bit 3 Conf. Reg. = 0	Yes
12	12	Remote 2 Temperature Offset Low Byte	0000 0000	Bit 3 Conf. Reg. = 1	Yes
13	13	Remote 1 Temperature High Limit Low Byte	0000 0000	Bit 3 Conf. Reg. = 0	Yes
13	13	Remote 2 Temperature High Limit Low Byte	0000 0000	Bit 3 Conf. Reg. = 1	Yes
14	14	Remote 1 Temperature Low Limit Low Byte	0000 0000	Bit 3 Conf. Reg. = 0	Yes
14	14	Remote 2 Temperature Low Limit Low Byte	0000 0000	Bit 3 Conf. Reg. = 1	Yes
19	19	Remote 1 <u>THERM</u> Limit	0101 0101 (0x55) (85°C)	Bit 3 Conf. Reg. = 0	Yes
19	19	Remote 2 <u>THERM</u> Limit	0101 0101 (0x55) (85°C)	Bit 3 Conf. Reg. = 1	Yes
20	20	Local <u>THERM</u> Limit	0101 0101 (0x55) (85°C)		Yes
21	21	<u>THERM</u> Hysteresis	0000 1010 (0x0A) (10°C)		Yes
22	22	Consecutive <u>ALERT</u>	0000 0001 (0x01)		Yes
23	N/A	Status Register 2	0000 0000 (0x00)		No
24	24	Configuration 2 Register	0000 0000 (0x00)		Yes
30	N/A	Remote 2 Temperature Value High Byte	0000 0000 (0x00)		No
31	31	Remote 2 Temperature High Limit High Byte	0101 0101 (0x55) (85°C)		Yes
32	32	Remote 2 Temperature Low Limit High Byte	0000 0000 (0x00) (0°C)		Yes
33	N/A	Remote 2 Temperature Value Low Byte	0000 0000 (0x00)		No
34	34	Remote 2 Temperature Offset High Byte	0000 0000 (0x00)		Yes
35	35	Remote 2 Temperature Offset Low Byte	0000 0000 (0x00)		Yes
36	36	Remote 2 Temperature High Limit Low Byte	0000 0000 (0x00) (0°C)		Yes
37	37	Remote 2 Temperature Low Limit Low Byte	0000 0000 (0x00) (0°C)		Yes
39	39	Remote 2 <u>THERM</u> Limit	0101 0101 (0x55) (85°C)		Yes
FE	N/A	Manufacturer ID	0100 0001 (0x41)		N/A
FF	N/A	Die Revision Code	0110 0101 (0x65)		N/A

¹ Writing to address 0F causes the ADT7482 to perform a single measurement. It is not a data register as such and it does not matter what data is written to it.

SERIAL BUS INTERFACE

Control of the ADT7482 is achieved via the serial bus. The ADT7482 is connected to this bus as a slave device, under the control of a master device.

The ADT7482 has an SMBus timeout feature. When this is enabled, the SMBus times out after typically 25 ms of no activity. However, this feature is not enabled by default. Set Bit 7 (SCL Timeout Bit) of the consecutive alert register (Address = 0x22) to enable the SCL Timeout. Set Bit 6 (SDA Timeout Bit) of the consecutive alert register (Address = 0x22) to enable the SDA Timeout.

Consult the SMBus 1.1 specification for more information.

ADDRESSING THE DEVICE

In general, every SMBus device has a 7-bit device address, except for some devices that have extended, 10-bit addresses. When the master device sends a device address over the bus, the slave device with that address responds. The ADT7482 is available with one device address, 0x4C (1001 100b). The address mentioned in this data sheet is a 7-bit address. The R/W bit needs to be added to arrive at an 8-bit address.

Serial Bus Protocol Operation

The master initiates data transfer by establishing a start condition, defined as a high-to-low transition on the serial data line SDATA while the serial clock line SCLK remains high. This indicates that an address/data stream follows.

All slave peripherals connected to the serial bus respond to the start condition and shift in the next eight bits, consisting of a 7-bit address (MSB first) plus an R/W bit, which determines the direction of the data transfer, that is, whether data is to be written to or read from the slave device. The peripheral whose address corresponds to the transmitted address responds by pulling the data line low during the low period before the ninth clock pulse, known as the acknowledge bit. All other devices on the bus now remain idle while the selected device waits for data to be read from or written to it. If the R/W bit is a 0, the master writes to the slave device. If the R/W bit is a 1, the master reads from the slave device.

Data is sent over the serial bus in a sequence of nine clock pulses, eight bits of data followed by an acknowledge bit from the slave device. Transitions on the data line must occur during the low period of the clock signal and remain stable during the high period, since a low-to-high transition when the clock is high can be interpreted as a stop signal. The number of data bytes that can be transmitted over the serial bus in a single read or write operation is limited only by what the master and slave devices can handle.

When all data bytes have been read or written, stop conditions are established. In write mode, the master pulls the data line high during the tenth clock pulse to assert a stop condition. In read mode, the master device overrides the acknowledge bit by pulling the data line high during the low period before the ninth clock pulse. This is known as no acknowledge. The master then takes the data line low during the low period before the tenth clock pulse, then high during the tenth clock pulse to assert a stop condition.

Any number of bytes of data can be transferred over the serial bus in one operation, but it is not possible to mix read and write in one operation because the type of operation is determined at the beginning and cannot subsequently be changed without starting a new operation. In the case of the ADT7482, write operations contain either one or two bytes, while read operations contain one byte.

To write data to one of the device data registers or to read data from it, the address pointer register must be set so that the correct data register is addressed. The first byte of a write operation always contains a valid address that is stored in the address pointer register. If data is to be written to the device, the write operation contains a second data byte that is written to the register selected by the address pointer register.

The device address is sent over the bus followed by $\overline{R/W}$ set to 0. This is followed by two data bytes. The first data byte is the address of the internal data register to be written to, which is stored in the address pointer register. The second data byte is the data to be written to the internal data register.

