

# MAX1720

## Switched Capacitor Voltage Inverter with Shutdown

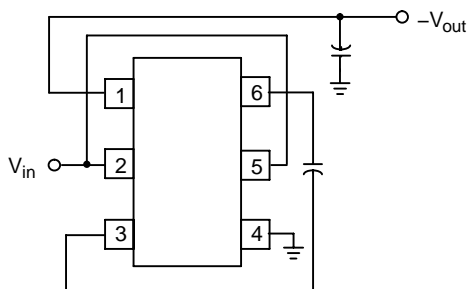
The MAX1720 is a CMOS charge pump voltage inverter that is designed for operation over an input voltage range of 1.15 V to 5.5 V with an output current capability in excess of 50 mA. The operating current consumption is only 67  $\mu$ A, and a power saving shutdown input is provided to further reduce the current to a mere 0.4  $\mu$ A. The device contains a 12 kHz oscillator that drives four low resistance MOSFET switches, yielding a low output resistance of 26  $\Omega$  and a voltage conversion efficiency of 99%. This device requires only two external 10  $\mu$ F capacitors for a complete inverter making it an ideal solution for numerous battery powered and board level applications. The MAX1720 is available in the space saving TSOP-6 package.

### Features

- Operating Voltage Range of 1.15 V to 5.5 V
- Output Current Capability in Excess of 50 mA
- Low Current Consumption of 67  $\mu$ A
- Power Saving Shutdown Input for a Reduced Current of 0.4  $\mu$ A
- Operation at 12 kHz
- Low Output Resistance of 26  $\Omega$
- Space Saving TSOP-6 Package
- Pb-Free Package is Available

### Typical Applications

- LCD Panel Bias
- Cellular Telephones
- Pagers
- Personal Digital Assistants
- Electronic Games
- Digital Cameras
- Camcorders
- Hand Held Instruments



This device contains 77 active transistors.  
**Figure 1. Typical Application**



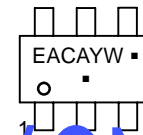
**ON Semiconductor**<sup>®</sup>

<http://onsemi.com>



**TSOP-6  
 SN SUFFIX  
 CASE 318G**

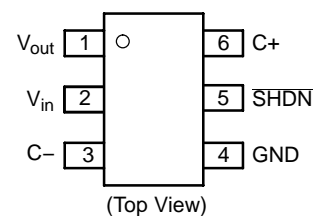
### MARKING DIAGRAM



EAC = Device Code  
 A = Assembly Location  
 Y = Year  
 W = Work Week  
 ■ = Pb-Free Package

(Note: Microdot may be in either location)

### PIN CONNECTIONS



### ORDERING INFORMATION

Device	Package	Shipping <sup>†</sup>
MAX1720EUT	TSOP-6	3000 Tape & Reel
MAX1720EUTG	TSOP-6 (Pb-Free)	3000 Tape & Reel

<sup>†</sup>For information on tape and reel specifications, including part orientation and tape sizes, please refer to our Tape and Reel Packaging Specifications Brochure, BRD8011/D.

# MAX1720

## MAXIMUM RATINGS\*

Rating	Symbol	Value	Unit
Input Voltage Range ( $V_{in}$ to GND)	$V_{in}$	-0.3 to 6.0	V
Output Voltage Range ( $V_{out}$ to GND)	$V_{out}$	-6.0 to 0.3	V
Output Current (Note 1)	$I_{out}$	100	mA
Output Short Circuit Duration ( $V_{out}$ to GND, Note 1)	$t_{SC}$	Indefinite	sec
Operating Junction Temperature	$T_J$	150	°C
Power Dissipation and Thermal Characteristics Thermal Resistance, Junction-to-Air Maximum Power Dissipation @ $T_A = 70^\circ\text{C}$	$R_{\theta JA}$ $P_D$	256 313	°C/W mW
Storage Temperature	$T_{stg}$	-55 to 150	°C

Maximum ratings are those values beyond which device damage can occur. Maximum ratings applied to the device are individual stress limit values (not normal operating conditions) and are not valid simultaneously. If these limits are exceeded, device functional operation is not implied, damage may occur and reliability may be affected.

### \*ESD Ratings

- ESD Machine Model Protection up to 200 V, Class B
- ESD Human Body Model Protection up to 2000 V, Class 2

## ELECTRICAL CHARACTERISTICS ( $V_{in} = 5.0\text{ V}$ , $C_1 = 10\ \mu\text{F}$ , $C_2 = 10\ \mu\text{F}$ , $T_A = -40^\circ\text{C}$ to $85^\circ\text{C}$ , typical values shown are for $T_A = 25^\circ\text{C}$ unless otherwise noted. See Figure 14 for Test Setup.)

Characteristic	Symbol	Min	Typ	Max	Unit
Operating Supply Voltage Range ( $\overline{\text{SHDN}} = V_{in}$ , $R_L = 10\text{ k}$ )	$V_{in}$	1.5 to 5.5	1.15 to 6.0	-	V
Supply Current Device Operating ( $\overline{\text{SHDN}} = 5.0\text{ V}$ , $R_L = \infty$ ) $T_A = 25^\circ\text{C}$ $T_A = 85^\circ\text{C}$	$I_{in}$	-	67 72	90 100	$\mu\text{A}$
Supply Current Device Shutdown ( $\overline{\text{SHDN}} = 0\text{ V}$ ) $T_A = 25^\circ\text{C}$ $T_A = 85^\circ\text{C}$	$I_{SHDN}$	-	0.4 1.6	-	$\mu\text{A}$
Oscillator Frequency $T_A = 25^\circ\text{C}$ $T_A = -40^\circ\text{C}$ to $85^\circ\text{C}$	$f_{OSC}$	3.4 6.0	12 L	15.6 21	kHz
Output Resistance ( $I_{out} = 25\text{ mA}$ , Note 2)	$R_{out}$	-	26	50	$\Omega$
Voltage Conversion Efficiency ( $R_L = \infty$ )	$V_{EFF}$	99	99.9	-	%
Power Conversion Efficiency ( $R_L = 1.0\text{ k}$ )	$P_{EFF}$	-	96	-	%
Shutdown Input Threshold Voltage ( $V_{in} = 1.5\text{ V}$ to $5.5\text{ V}$ ) High State, Device Operating Low State, Device Shutdown	$V_{th}(\overline{\text{SHDN}})$	-	$0.6 V_{in}$ $0.5 V_{in}$	-	V
Shutdown Input Bias Current High State, Device Operating, $\overline{\text{SHDN}} = 5.0\text{ V}$ $T_A = 25^\circ\text{C}$ $T_A = 85^\circ\text{C}$ Low State, Device Shutdown, $\overline{\text{SHDN}} = 0\text{ V}$ $T_A = 25^\circ\text{C}$ $T_A = 85^\circ\text{C}$	$I_{IH}$  $I_{IL}$	-	5.0 100	-	pA
Wake-Up Time from Shutdown ( $R_L = 1.0\text{ k}$ )	$t_{WKUP}$	-	1.2	-	ms

1. Maximum Package power dissipation limits must be observed to ensure that the maximum junction temperature is not exceeded.

$$T_J = T_A + (P_D R_{\theta JA})$$

2. Capacitors  $C_1$  and  $C_2$  contribution is approximately 20% of the total output resistance.

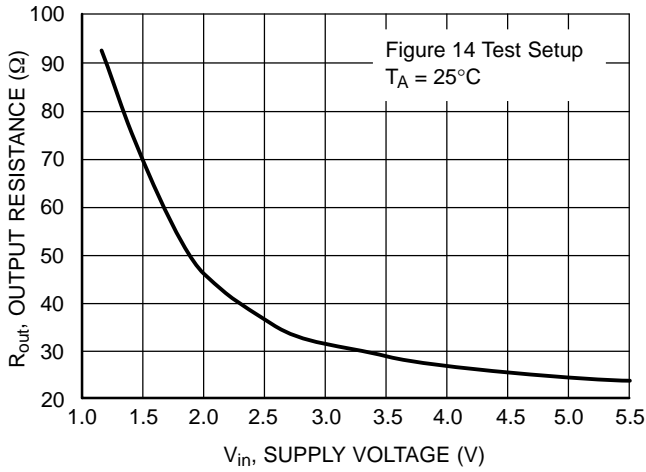


Figure 2. Output Resistance vs. Supply Voltage

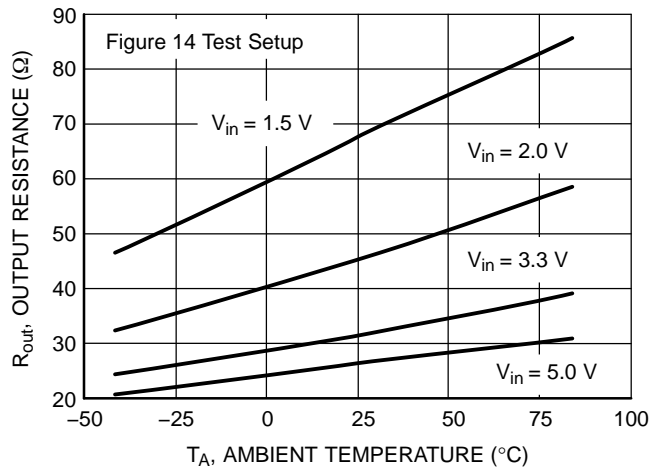


Figure 3. Output Resistance vs. Ambient Temperature

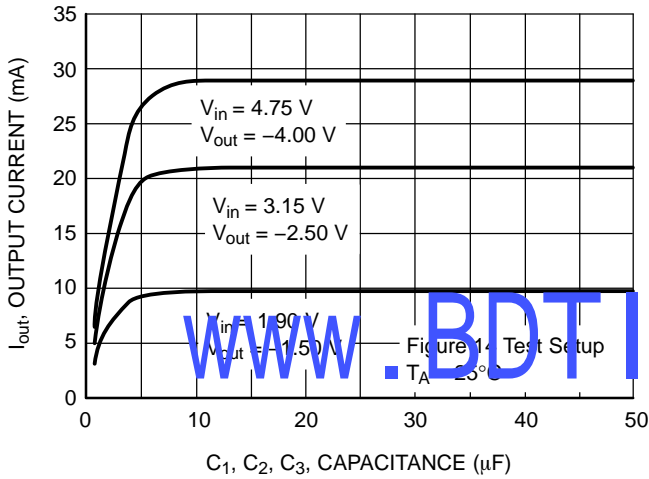


Figure 4. Output Current vs. Capacitance

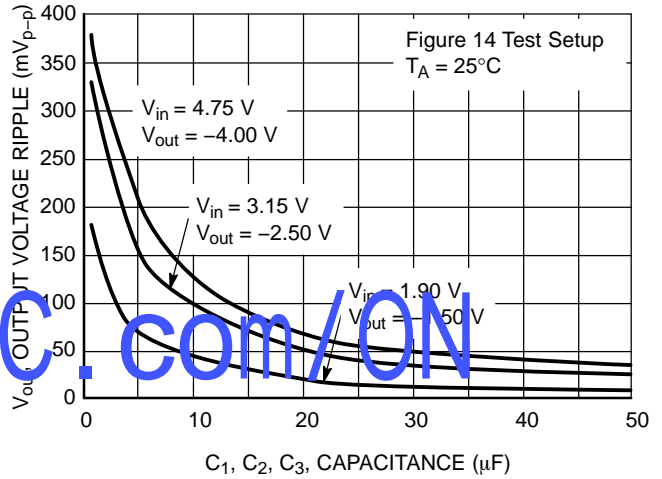


Figure 5. Output Voltage Ripple vs. Capacitance

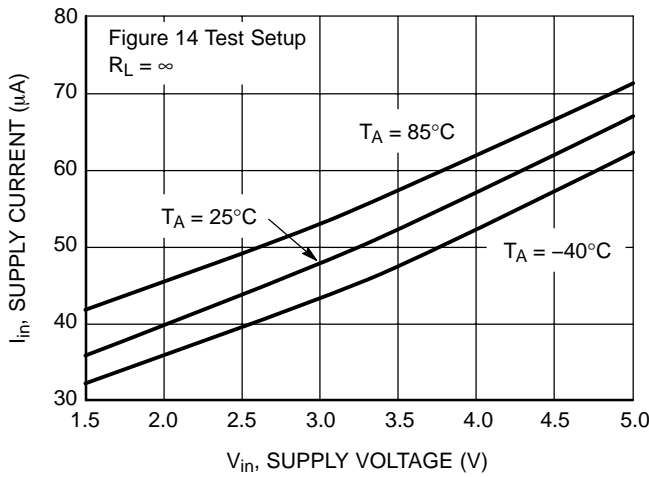


Figure 6. Supply Current vs. Supply Voltage

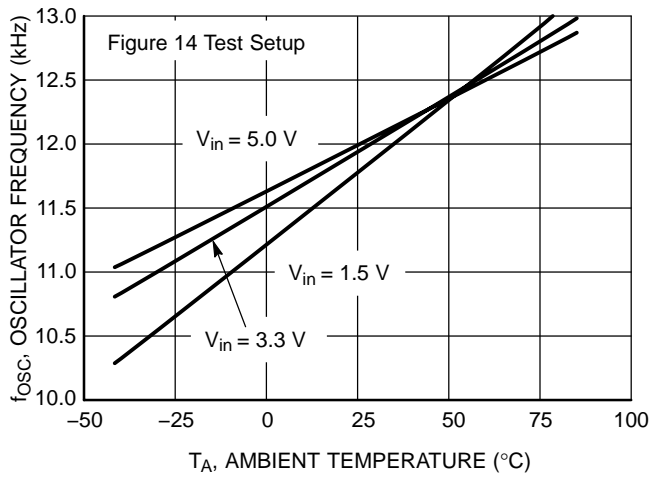


Figure 7. Oscillator Frequency vs. Ambient Temperature

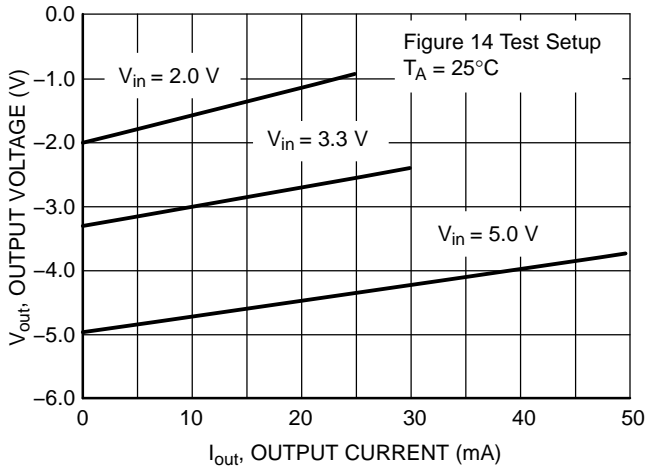


Figure 8. Output Voltage vs. Output Current

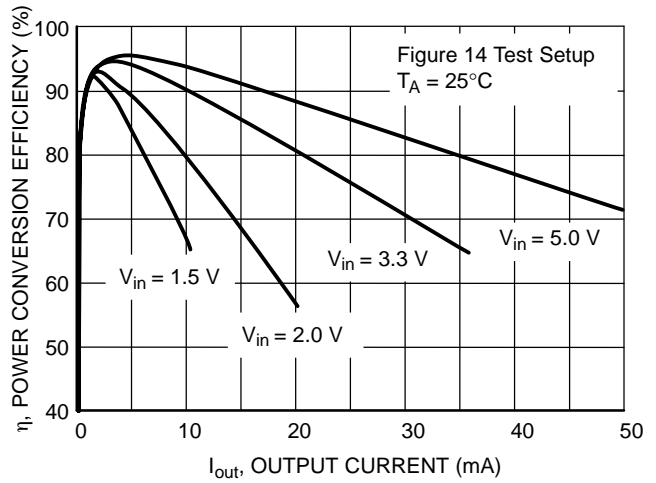


Figure 9. Power Conversion Efficiency vs. Output Current

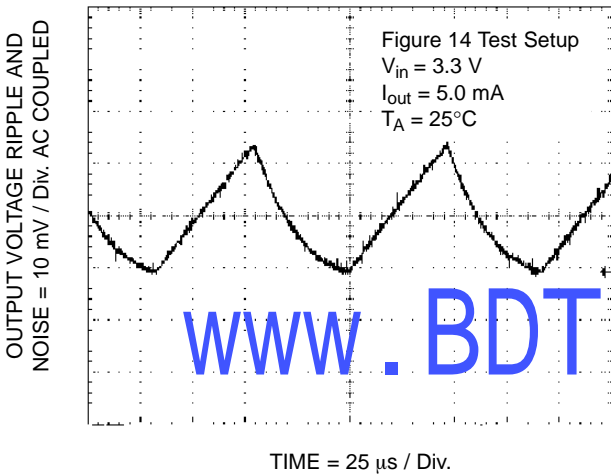


Figure 10. Output Voltage Ripple and Noise

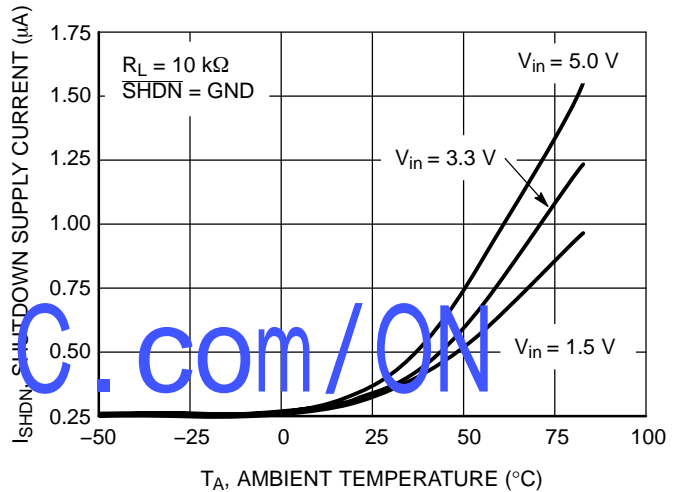


Figure 11. Shutdown Supply Current vs. Ambient Temperature

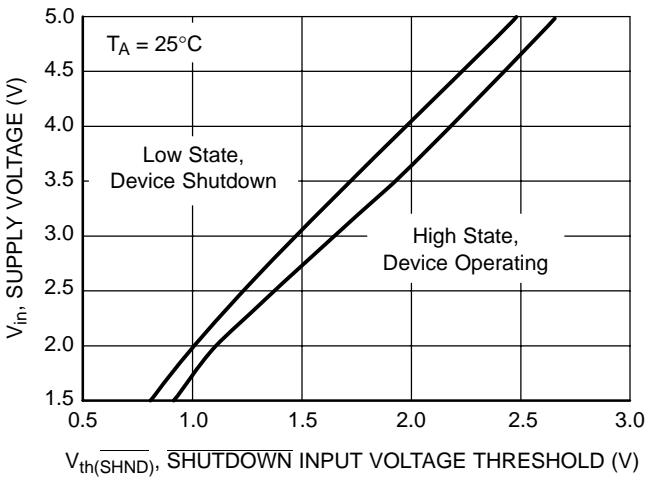


Figure 12. Supply Voltage vs. Shutdown Input Voltage Threshold

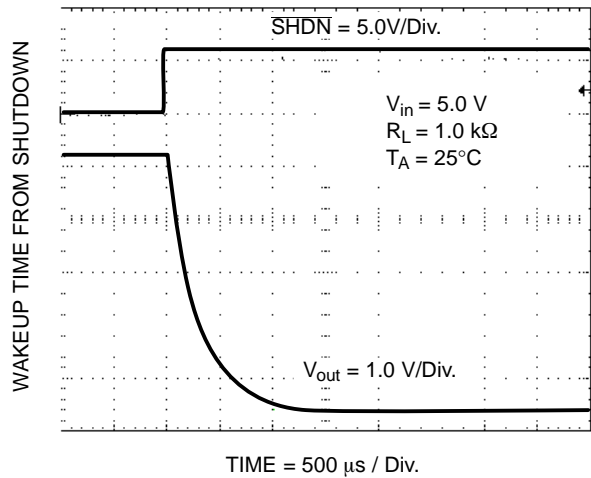


Figure 13. Wakeup Time From Shutdown

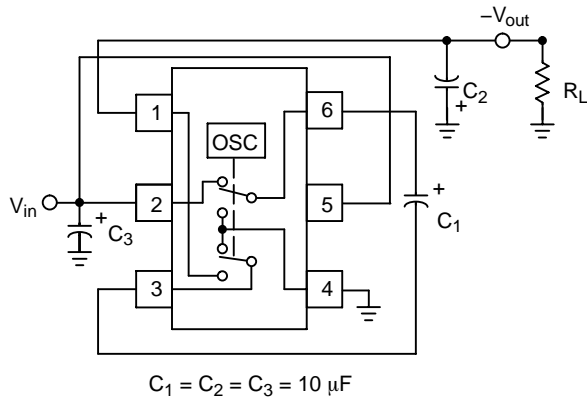


Figure 14. Test Setup/Voltage Inverter

**DETAILED OPERATING DESCRIPTION**

The MAX1720 charge pump converter inverts the voltage applied to the  $V_{in}$  pin. Conversion consists of a two-phase operation (Figure 15). During the first phase, switches  $S_2$  and  $S_4$  are open and  $S_1$  and  $S_3$  are closed. During this time,  $C_1$  charges to the voltage on  $V_{in}$  and load current is supplied from  $C_2$ . During the second phase,  $S_2$  and  $S_4$  are closed, and  $S_1$  and  $S_3$  are open. This action connects  $C_1$  across  $C_2$ , restoring charge to  $C_2$ .

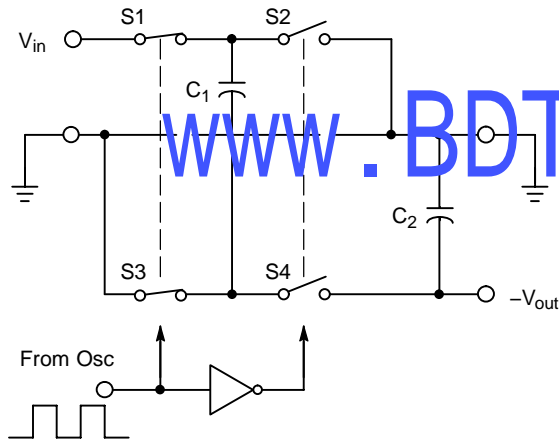


Figure 15. Ideal Switched Capacitor Charge Pump

**APPLICATIONS INFORMATION**

**Output Voltage Considerations**

The MAX1720 performs voltage conversion but does not provide regulation. The output voltage will drop in a linear manner with respect to load current. The value of this equivalent output resistance is approximately  $26 \Omega$  nominal at  $25^\circ\text{C}$  with  $V_{in} = 5.0 \text{ V}$ .  $V_{out}$  is approximately  $-5.0 \text{ V}$  at light loads, and drops according to the equation below:

$$V_{DROP} = I_{out} \times R_{out}$$

$$V_{out} = -(V_{in} - V_{DROP})$$

**Charge Pump Efficiency**

The overall power conversion efficiency of the charge pump is affected by four factors:

1. Losses from power consumed by the internal oscillator, switch drive, etc. (which vary with input voltage, temperature and oscillator frequency).
2.  $I^2R$  losses due to the on-resistance of the MOSFET switches on-board the charge pump.
3. Charge pump capacitor losses due to Equivalent Series Resistance (ESR).
4. Losses that occur during charge transfer from the commutation capacitor to the output capacitor when a voltage difference between the two capacitors exists.

Most of the conversion losses are due to factors 2, 3 and 4. These losses are given by Equation 1.

$$P_{LOSS(2,3,4)} = I_{out}^2 \times R_{out} \cong I_{out}^2 \times \left[ \frac{1}{(f_{OSC})C_1} + 8R_{SWITCH} + 4ESR_{C_1} + ESR_{C_2} \right]$$

(eq. 1)

The  $1/(f_{OSC})(C_1)$  term in Equation 1 is the effective output resistance of an ideal switched capacitor circuit (Figures 16 and 17).

The losses due to charge transfer above are also shown in Equation 2. The output voltage ripple is given by Equation 3.

$$P_{LOSS} = [0.5C_1 (V_{in}^2 - V_{out}^2) - 0.5C_2 (V_{RIPPLE}^2 - 2V_{out}V_{RIPPLE})] \times f_{OSC}$$

(eq. 2)

$$V_{RIPPLE} = \frac{I_{out}}{(f_{OSC})(C_2)} + 2(I_{out})(ESR_{C_2})$$

(eq. 3)

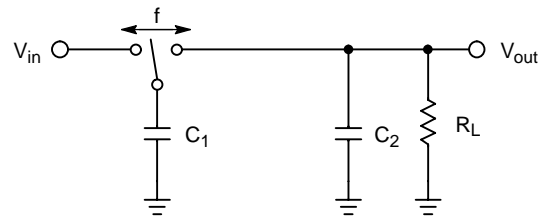


Figure 16. Ideal Switched Capacitor Model

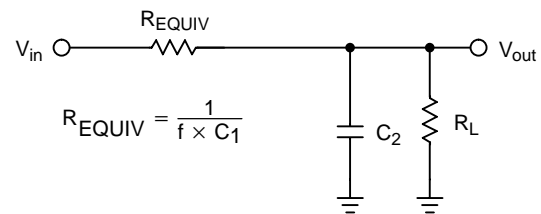


Figure 17. Equivalent Output Resistance

**Capacitor Selection**

In order to maintain the lowest output resistance and output ripple voltage, it is recommended that low ESR capacitors be used. Additionally, larger values of  $C_1$  will lower the output resistance and larger values of  $C_2$  will reduce output voltage ripple. (See Equation 3).

Table 1 shows various values of  $C_1$ ,  $C_2$  and  $C_3$  with the corresponding output resistance values at 25°C. Table 2 shows the output voltage ripple for various values of  $C_1$ ,  $C_2$  and  $C_3$ . The data in Tables 1 and 2 was measured not calculated.

**Table 1. Output Resistance vs. Capacitance**  
( $C_1 = C_2 = C_3$ ),  $V_{in} = 4.75\text{ V}$  and  $V_{out} = -4.0\text{ V}$

$C_1 = C_2 = C_3$ ( $\mu\text{F}$ )	$R_{out}$ ( $\Omega$ )
0.7	129.1
1.4	69.5
3.3	37.0
7.3	26.5
10	25.9
24	24.1
50	24

**Table 2. Output Voltage Ripple vs. Capacitance**  
( $C_1 = C_2 = C_3$ ),  $V_{in} = 4.75\text{ V}$  and  $V_{out} = -4.0\text{ V}$

$C_1 = C_2 = C_3$ ( $\mu\text{F}$ )	Output Voltage Ripple (mV)
0.7	382
1.4	342
3.3	255
7.3	164
10	132
24	59
50	38

**Input Supply Bypassing**

The input voltage,  $V_{in}$  should be capacitively bypassed to reduce AC impedance and minimize noise effects due to the switching internals in the device. If the device is loaded from  $V_{out}$  to GND, it is recommended that a large value capacitor (at least equal to  $C_1$ ) be connected from  $V_{in}$  to GND. If the device is loaded from  $V_{in}$  to  $V_{out}$ , a small ( $0.7\ \mu\text{F}$ ) capacitor between the pins is sufficient.

**Voltage Inverter**

The most common application for a charge pump is the voltage inverter (Figure 14). This application uses two or three external capacitors. The  $C_1$  (pump capacitor) and  $C_2$  (output capacitor) are required. The input bypass capacitor,  $C_3$ , may be necessary depending on the application. The output is equal to  $-V_{in}$  plus any voltage drops due to loading. Refer to Tables 1 and 2 for capacitor selection. The test setup used for the majority of the characterization is shown in Figure 14.

**Layout Considerations**

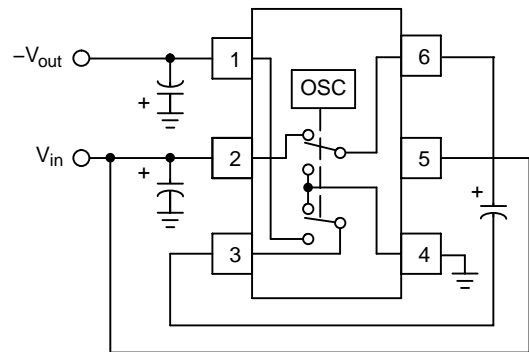
As with any switching power supply circuit, good layout practice is recommended. Mount components as close together as possible to minimize stray inductance and capacitance. Also, use a large ground plane to minimize noise leakage into other circuitry.

**Capacitor Resources**

Selecting the proper type of capacitor can reduce switching loss. Low ESR capacitors are recommended. The MAX1720 was characterized using the capacitors listed in Table 3. This list identifies low ESR capacitors for the voltage inverter application.

**Table 3. Capacitor Types**

Manufacturer/Contact	Part Types/Series
<b>AVX</b> 843-448-9411 www.avxcorp.com	TPS
<b>Cornell Dubilier</b> 508-996-8561 www.cornell-dubilier.com	ESRD
<b>Sanyo/Os-con</b> 619-661-6835 www.sanyovideo.com/oscon.htm	SN SVP
<b>Vishay</b> 603-224-1961 www.vishay.com	593D 594



Capacitors = 10  $\mu\text{F}$

**Figure 18. Voltage Inverter**

# MAX1720

The MAX1720 primary function is a voltage inverter. The device will convert 5.0 V into -5.0 V with light loads. Two capacitors are required for the inverter to function. A third capacitor, the input bypass capacitor, may be required depending on the power source for the inverter. The performance for this device is illustrated below.

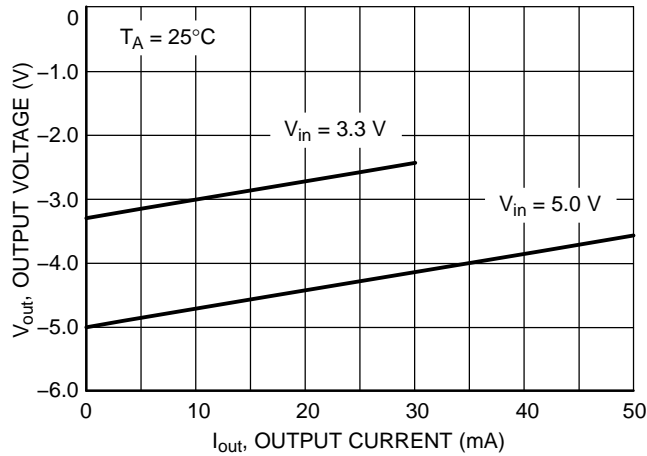


Figure 19. Inverter Load Regulation, Output Voltage vs. Output Current

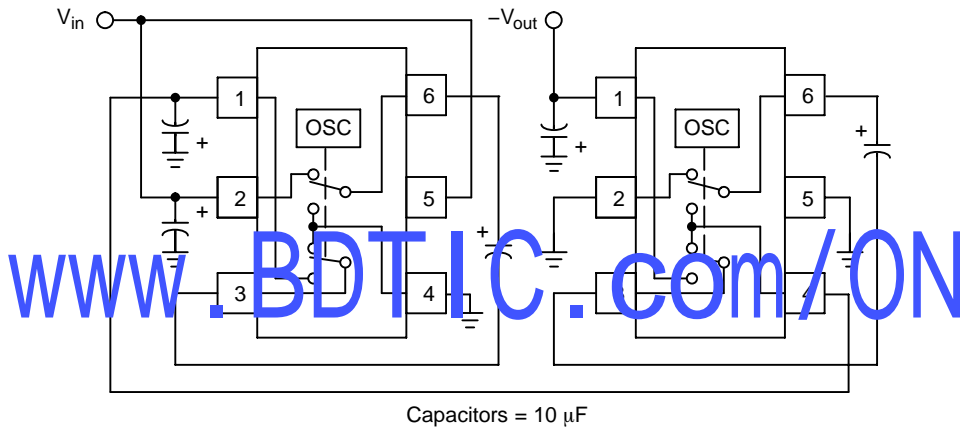
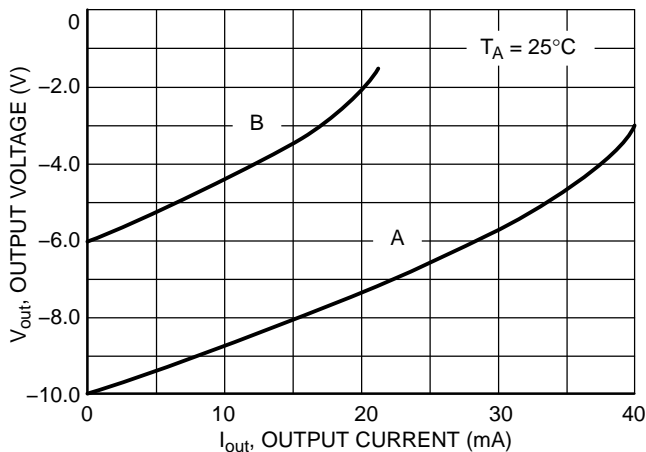


Figure 20. Cascaded Devices for Increased Negative Output Voltage

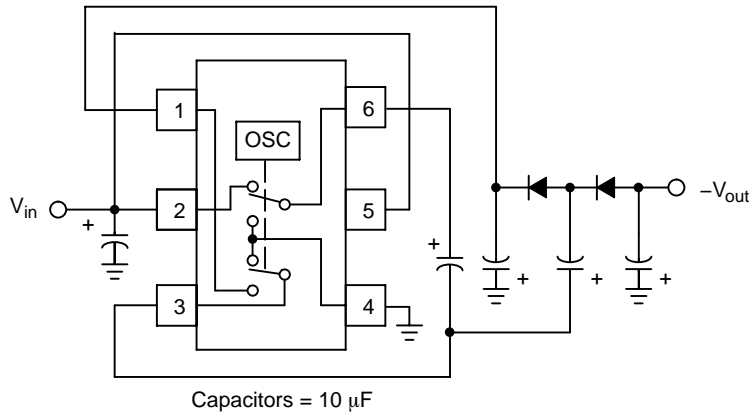
Two or more devices can be cascaded for increased output voltage. Under light load conditions, the output voltage is approximately equal to  $-V_{in}$  times the number of stages. The converter output resistance increases dramatically with each additional stage. This is due to a reduction of input voltage to each successive stage as the converter output is loaded. Note that the ground connection for each successive stage must connect to the negative output of the previous stage. The performance characteristics for a converter consisting of two cascaded devices are shown below.



Curve	$V_{in}$ (V)	$R_{out}$ ( $\Omega$ )
A	5.0	140
B	3.0	174

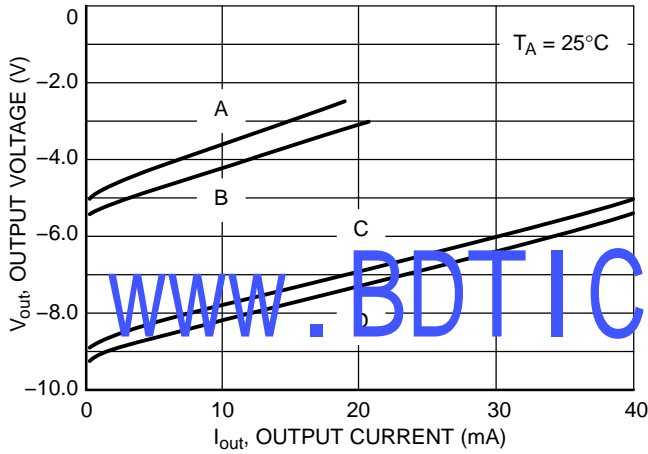
Figure 21. Cascade Load Regulation, Output Voltage vs. Output Current

# MAX1720



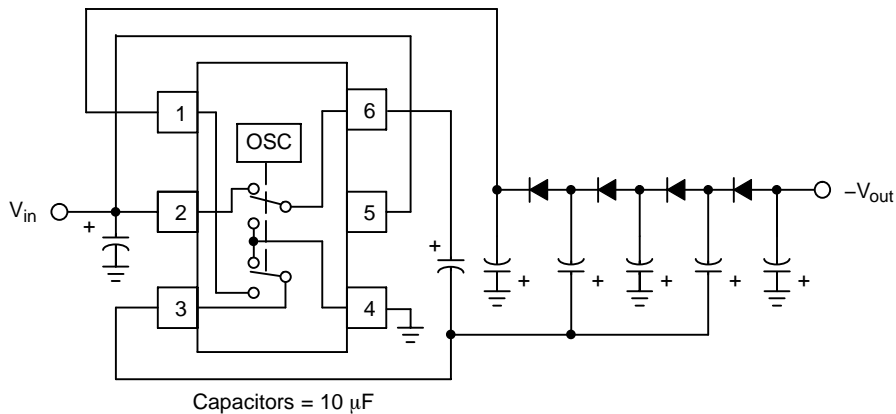
**Figure 22. Negative Output Voltage Doubler**

A single device can be used to construct a negative voltage doubler. The output voltage is approximately equal to  $-2V_{in}$  minus the forward voltage drop of each external diode. The performance characteristics for the above converter are shown below. Note that curves A and C show the circuit performance with economical 1N4148 diodes, while curves B and D are with lower loss MBRA120E Schottky diodes.



Curve	$V_{in}$ (V)	All Diodes	$R_{out}$ ( $\Omega$ )
A	3.0	1N4148	124
B	3.0	MBRA120E	115
C	5.0	1N4148	96
D	5.0	MBRA120E	94

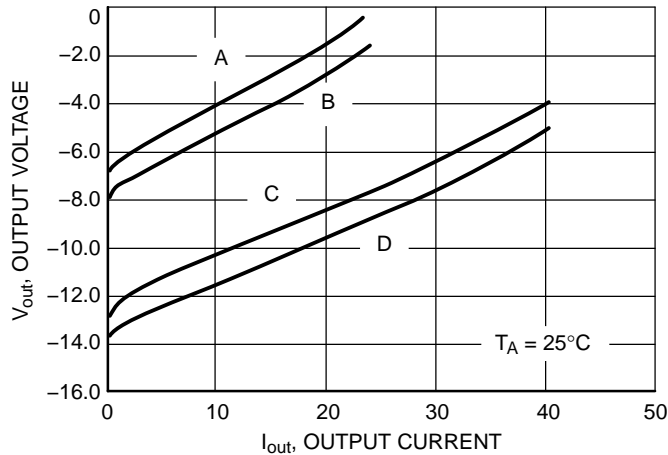
**Figure 23. Doubler Load Regulation, Output Voltage vs. Output Current**



**Figure 24. Negative Output Voltage Tripler**

## MAX1720

A single device can be used to construct a negative voltage tripler. The output voltage is approximately equal to  $-3V_{in}$  minus the forward voltage drop of each external diode. The performance characteristics for the above converter are shown below. Note that curves A and C show the circuit performance with economical 1N4148 diodes, while curves B and D are with lower loss MBRA120E Schottky diodes.



Curve	$V_{in}$ (V)	All Diodes	$R_{out}$ ( $\Omega$ )
A	3.0	1N4148	267
B	3.0	MBRA120E	250
C	5.0	1N4148	205
D	5.0	MBRA120E	195

Figure 25. Tripler Load Regulation, Output Voltage vs. Output Current

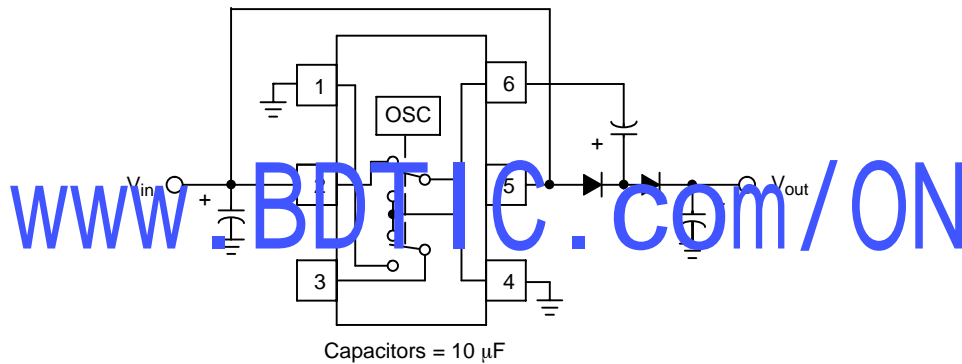
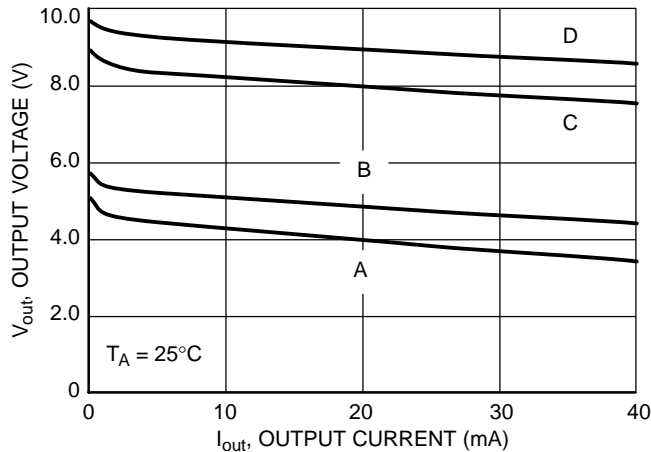


Figure 26. Positive Output Voltage Doubler

A single device can be used to construct a positive voltage doubler. The output voltage is approximately equal to  $2V_{in}$  minus the forward voltage drop of each external diode. The performance characteristics for the above converter are shown below. Note that curves A and C show the circuit performance with economical 1N4148 diodes, while curves B and D are with lower loss MBRA120E Schottky diodes.



Curve	$V_{in}$ (V)	All Diodes	$R_{out}$ ( $\Omega$ )
A	3.0	1N4148	32
B	3.0	MBRA120E	26
C	5.0	1N4148	26
D	5.0	MBRA120E	21

Figure 27. Doubler Load Regulation, Output Voltage vs. Output Current

## MAX1720

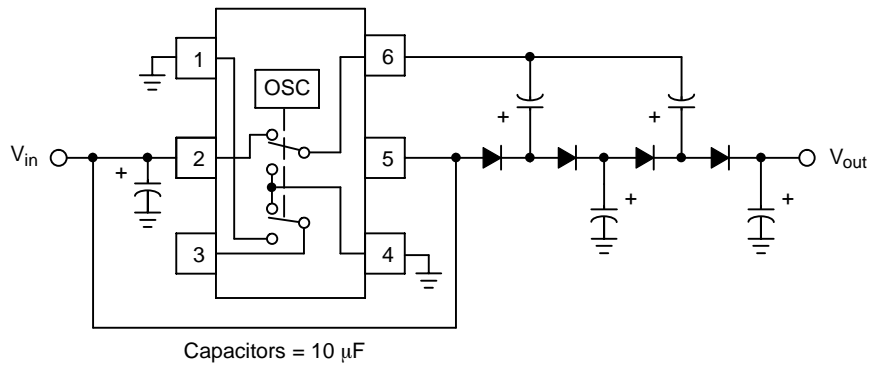
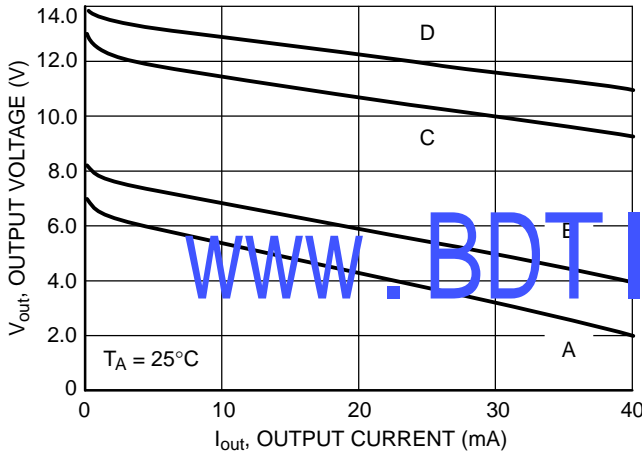


Figure 28. Positive Output Voltage Tripler

A single device can be used to construct a positive voltage tripler. The output voltage is approximately equal to  $3V_{in}$  minus the forward voltage drop of each external diode. The performance characteristics for the above converter are shown below. Note that curves A and C show the circuit performance with economical 1N4148 diodes, while curves B and D are with lower loss MBRA120E Schottky diodes.



Curve	$V_{in}$ (V)	All Diodes	$R_{out}$ ( $\Omega$ )
A	3.0	1N4148	111
B	3.0	MBRA120E	97
C	5.0	1N4148	85
D	5.0	MBRA120E	75

Figure 29. Tripler Load Regulation, Output Voltage vs. Output Current

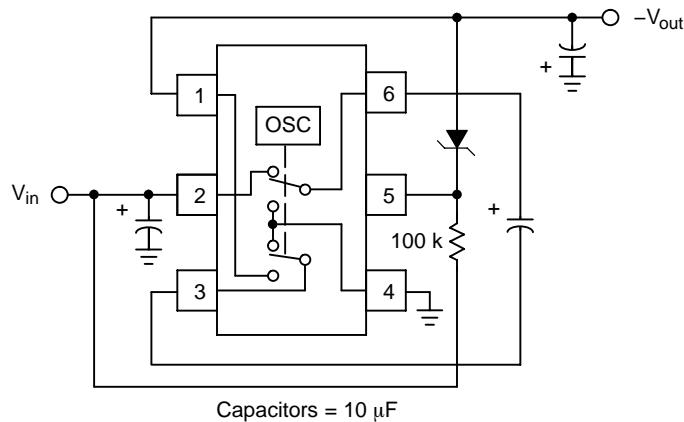
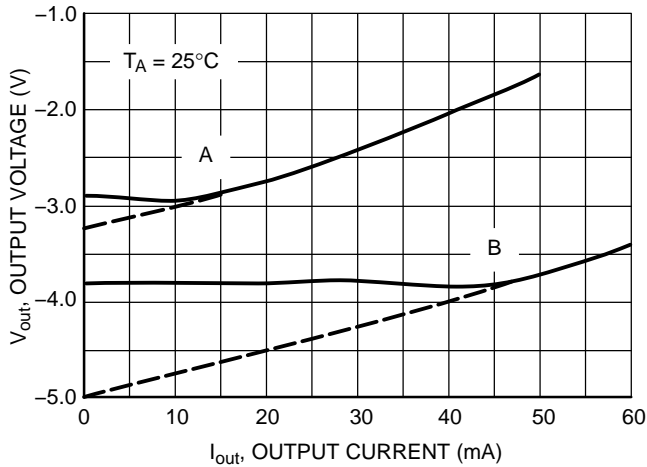


Figure 30. Load Regulated Negative Output Voltage

## MAX1720

A zener diode can be used with the shutdown input to provide closed loop regulation performance. This significantly reduces the converter's output resistance and dramatically enhances the load regulation. For closed loop operation, the desired regulated output voltage must be lower in magnitude than  $-V_{in}$ . The output will regulate at a level of  $-V_z + V_{th(SHDN)}$ . Note that the shutdown input voltage threshold is typically  $0.5 V_{in}$  and therefore, the regulated output voltage will change proportional to the converter's input. This characteristic will not present a problem when used in applications with constant input voltage. In this case the zener breakdown was measured at  $25 \mu\text{A}$ . The performance characteristics for the above converter are shown below. Note that the dashed curve sections represent the converter's open loop performance.



Curve	$V_{in}$ (V)	$V_z$ (V)	$V_{out}$ (V)
A	3.3 V	4.5	-2.8
B	5.0 V	6.5	-3.8

Figure 31. Load Regulation, Output Voltage vs. Output Current

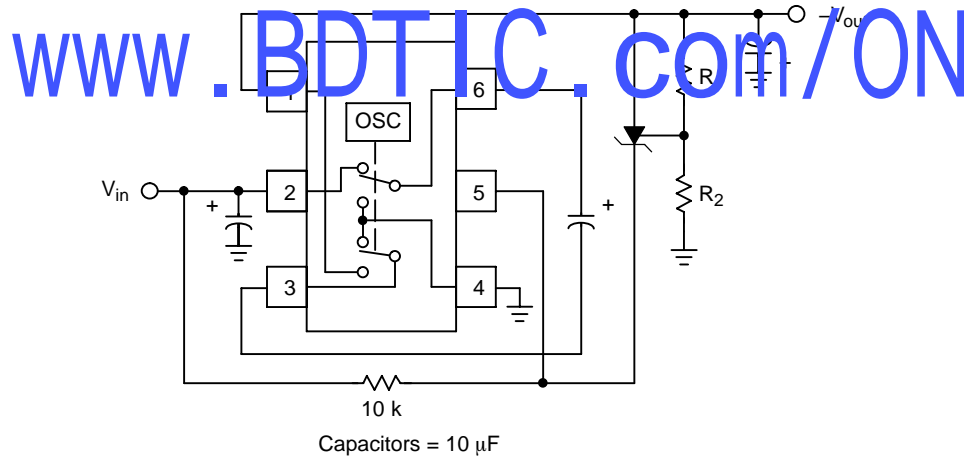
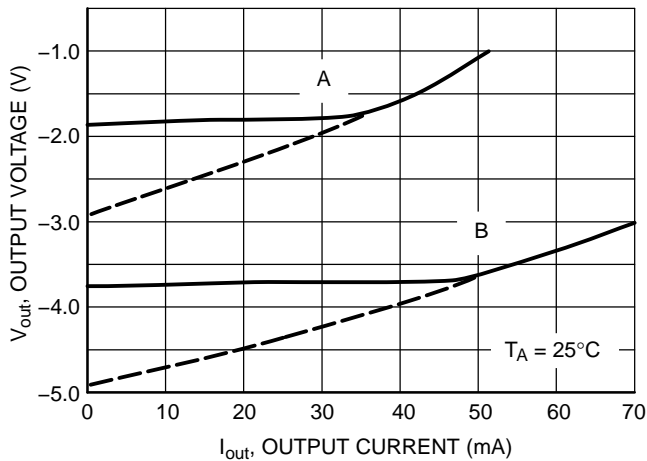


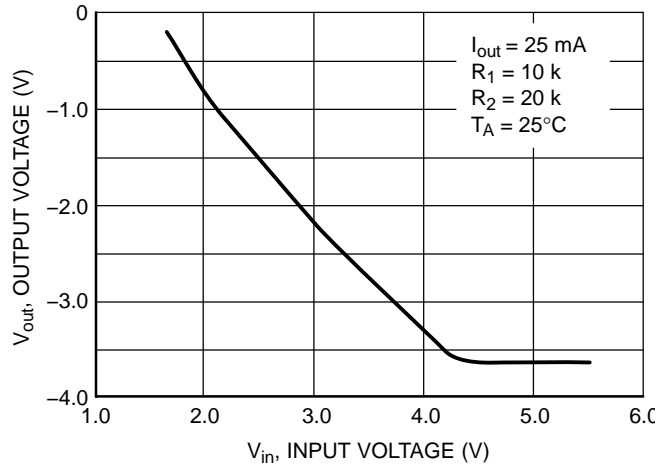
Figure 32. Line and Load Regulated Negative Output Voltage

# MAX1720

An adjustable shunt regulator can be used with the shutdown input to give excellent closed loop regulation performance. The shunt regulator acts as a comparator with a precise input offset voltage which significantly reduces the converter's output resistance and dramatically enhances the line and load regulation. For closed loop operation, the desired regulated output voltage must be lower in magnitude than  $-V_{in}$ . The output will regulate at a level of  $-V_{ref} (R_2/R_1 + 1)$ . The adjustable shunt regulator can be from either the TLV431 or TL431 families. The comparator offset or reference voltage is 1.25 V or 2.5 V respectively. The performance characteristics for the converter are shown below. Note that the dashed curve sections represent the converter's open loop performance.

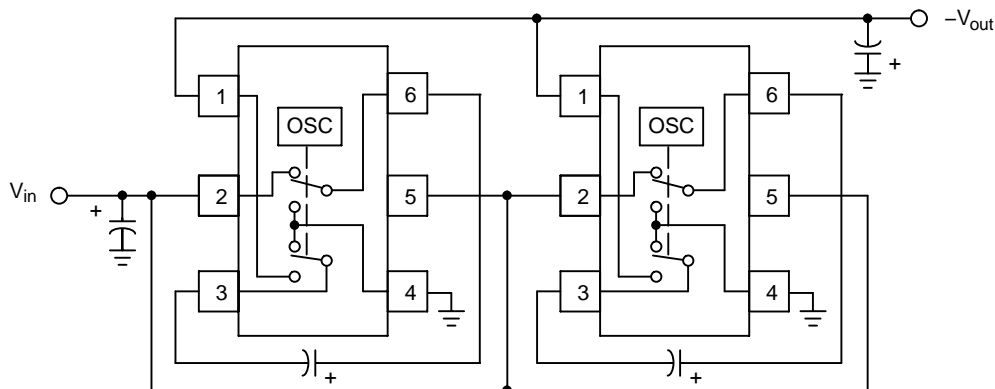


**Figure 33. Load Regulation, Output Voltage vs. Output Current**



**Figure 34. Line Regulation, Output Voltage vs. Input Current**

Curve	$V_{in}$ (V)	$R_1$ ( $\Omega$ )	$R_2$ ( $\Omega$ )	$V_{out}$ (V)
A	3.0	10 k	5.0 k	-1.8
B	5.0	10 k	20 k	-3.5



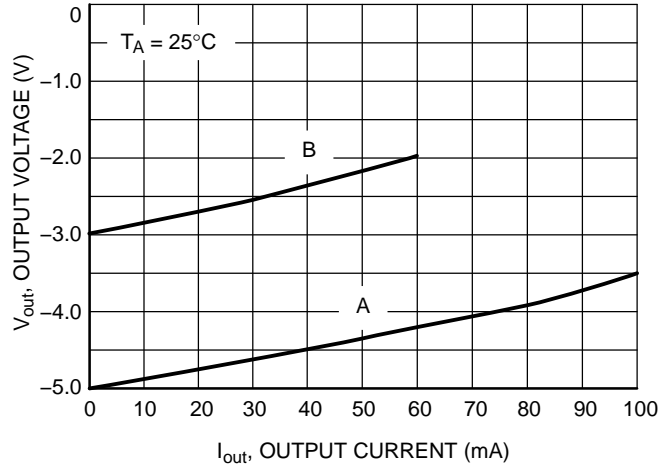
Capacitors = 10  $\mu$ F

**Figure 35. Paralleling Devices for Increased Negative Output Current**

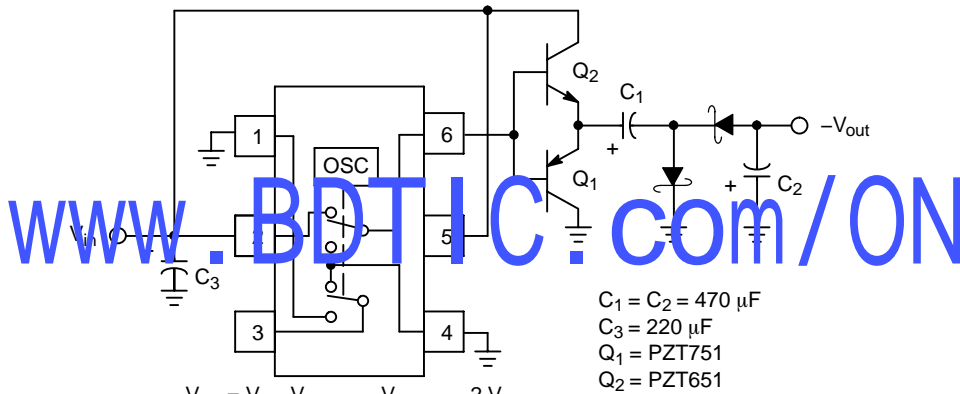
# MAX1720

An increase in converter output current capability with a reduction in output resistance can be obtained by paralleling two or more devices. The output current capability is approximately equal to the number of devices paralleled. A single shared output capacitor is sufficient for proper operation but each device does require it's own pump capacitor. Note that the output ripple frequency will be complex since the oscillators are not synchronized. The performance characteristics for a converter consisting of two paralleled devices is shown below.

Curve	V <sub>in</sub> (V)	R <sub>out</sub> (Ω)
A	5.0	14.5
B	3.0	17

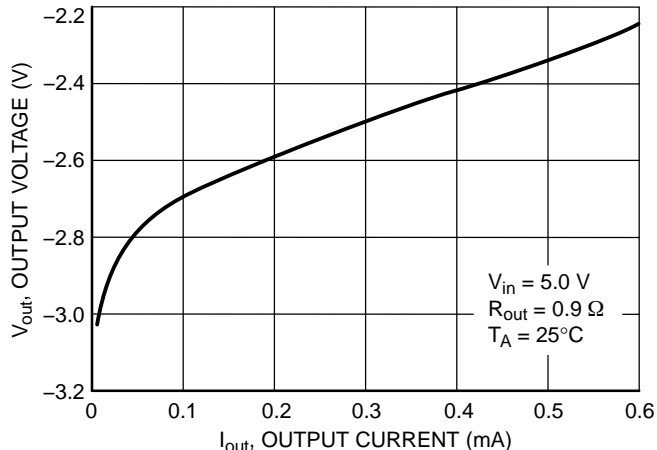


**Figure 36. Parallel Load Regulation, Output Voltage vs. Output Current**



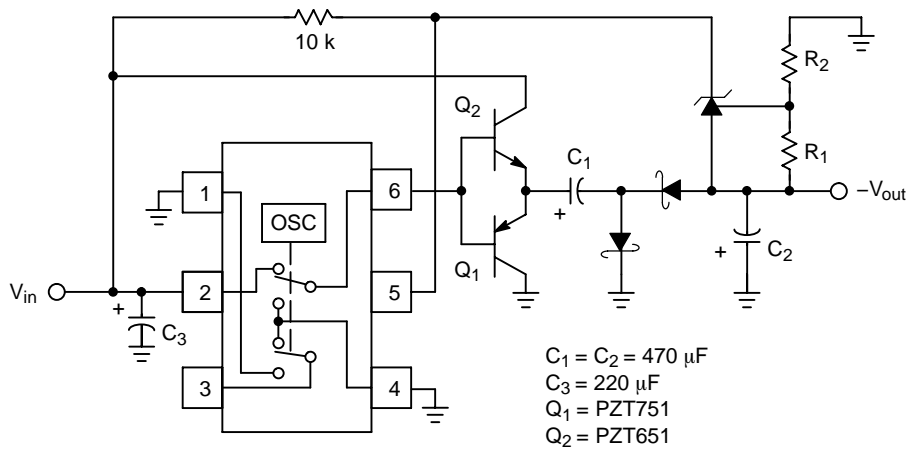
**Figure 37. External Switch for Increased Negative Output Current**

The output current capability of the MAX1720 can be extended beyond 600 mA with the addition of two external switch transistors and two Schottky diodes. The output voltage is approximately equal to  $-V_{in}$  minus the sum of the base emitter drops of both transistors and the forward voltage of both diodes. The performance characteristics for the converter are shown below. Note that the output resistance is reduced to  $0.9 \Omega$ .



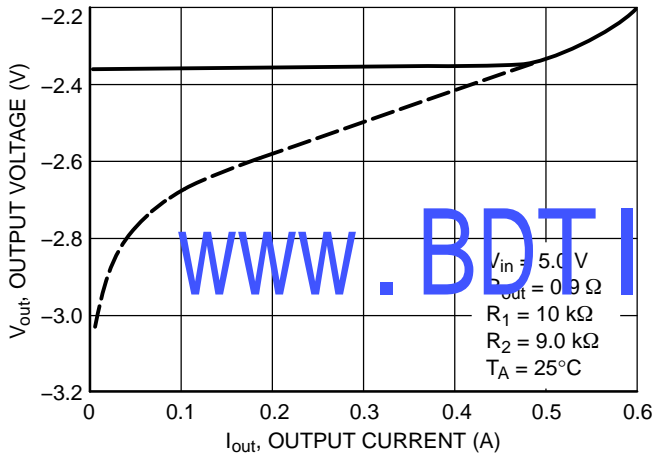
**Figure 38. Current Boosted Load Regulation, Output Voltage vs. Output Current**

## MAX1720

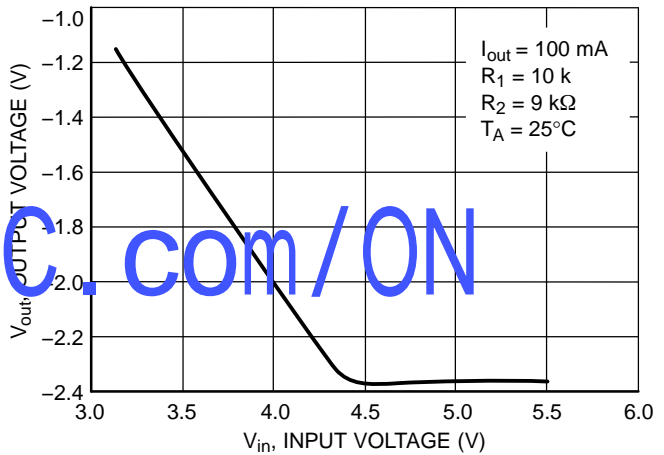


**Figure 39. Line and Load Regulated Negative Output Voltage with High Current Capability**

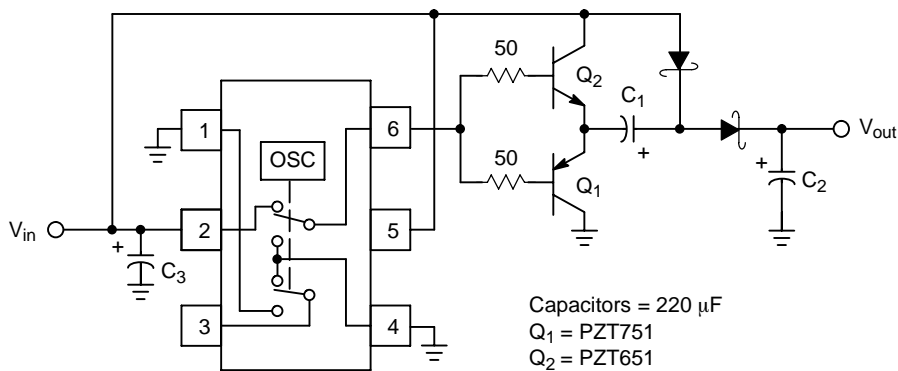
This converter is a combination of Figures 37 and 32. It provides a line and load regulated output of  $-2.36 \text{ V}$  at up to  $450 \text{ mA}$  with an input voltage of  $5.0 \text{ V}$ . The output will regulate at a level of  $-V_{\text{ref}}(R_2/R_1 + 1)$ . The performance characteristics are shown below. Note, the dashed line is the open loop and the solid line is the closed loop performance.



**Figure 40. Current Boosted Load Regulation, Output Voltage vs. Output Current**



**Figure 41. Current Boosted Line Regulation, Output Voltage vs. Input Voltage**



**Figure 42. Positive Output Voltage Doubler with High Current Capability**

# MAX1720

The MAX1720 can be configured to produce a positive output voltage doubler with current capability in excess of 500 mA. This is accomplished with the addition of two external switch transistors and two Schottky diodes. The output voltage is approximately equal to  $2V_{in}$  minus the sum of the base emitter drops of both transistors and the forward voltage of both diodes. The performance characteristics for the converter is shown below. Note that the output resistance is reduced to  $1.9 \Omega$ .

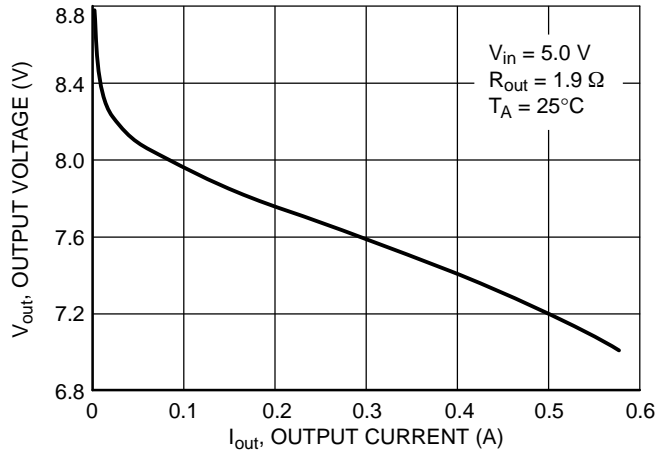


Figure 43. Positive Doubler with Current Boosted Load Regulation, Output Voltage vs. Output Current

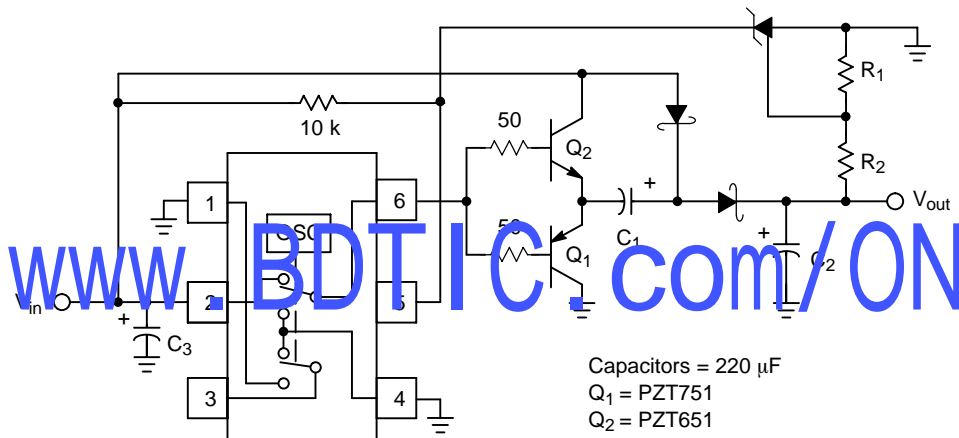


Figure 44. Line and Load Regulated Positive Output Voltage Doubler with High Current Capability

This converter is a combination of Figures 42 and the shunt regulator to close the loop. In this case the anode of the regulator is connected to ground. This convert provides a line and load regulated output of 7.6 V at up to 300 mA with an input voltage of 5.0 V. The output will regulate at a level of  $V_{ref} (R_2/R_1 + 1)$ . The open loop configuration is the dashed line and the closed loop is the solid line. The performance characteristics are shown below.

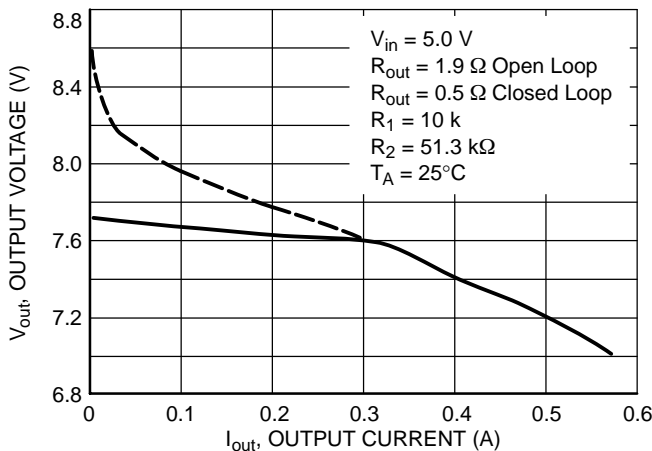


Figure 45. Current Boosted Close Loop Load Regulation, Output Voltage vs. Output Current

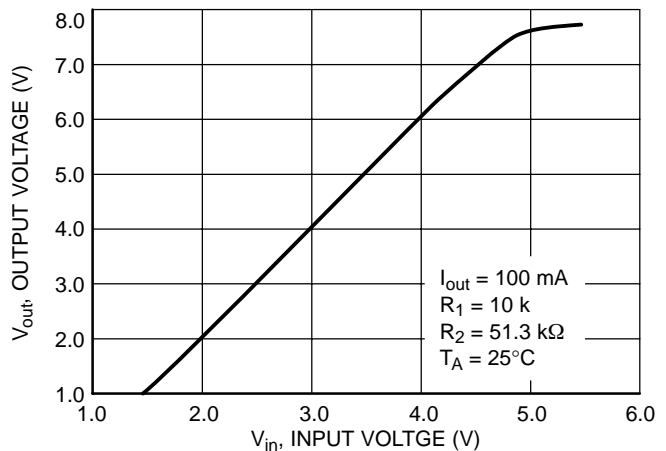
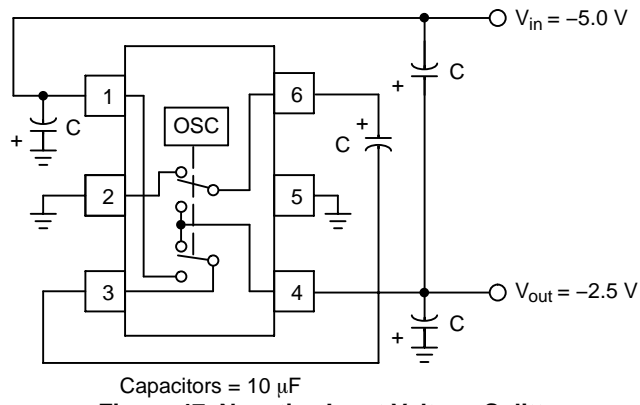


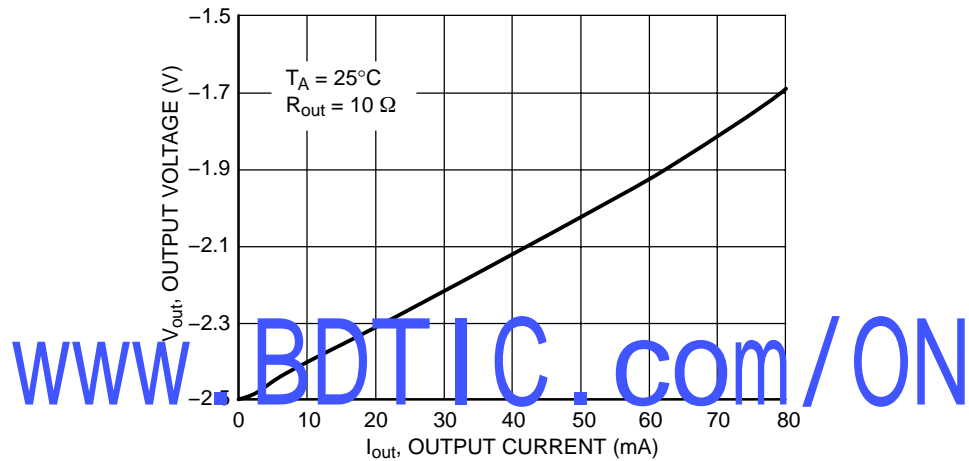
Figure 46. Current Boosted Close Loop Line Regulation, Output Voltage vs. Input Voltage

# MAX1720

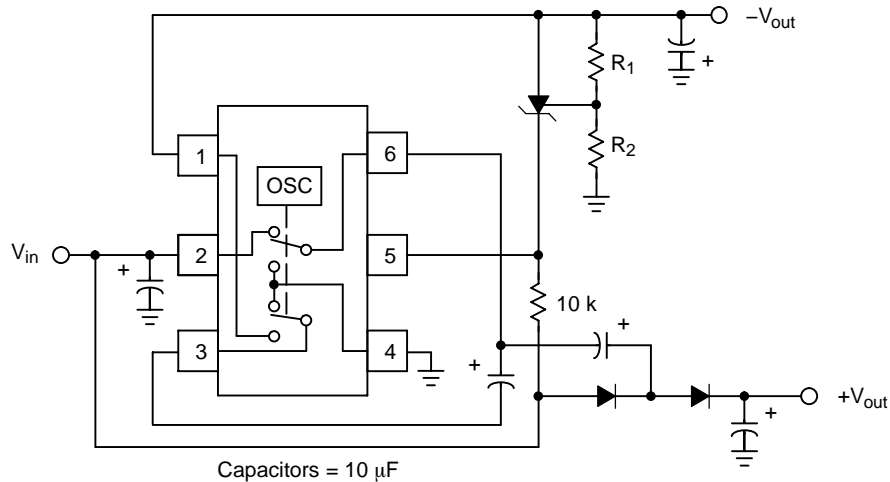


**Figure 47. Negative Input Voltage Splitter**

A single device can be used to split a negative input voltage. The output voltage is approximately equal to  $-V_{in}/2$ . The performance characteristics are shown below. Note that the converter has an output resistance of 10  $\Omega$ .



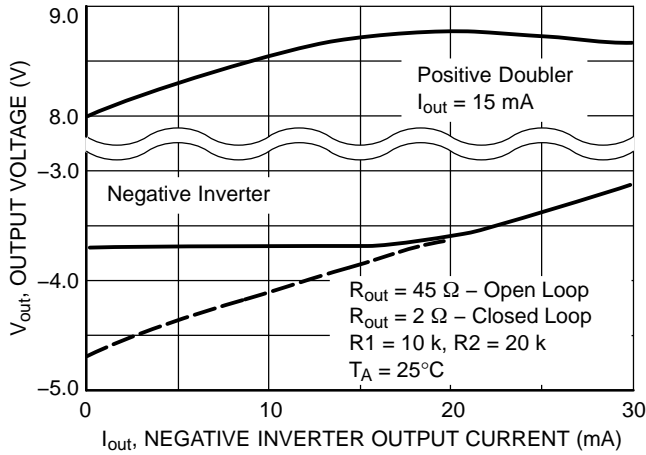
**Figure 48. Negative Voltage Splitter Load Regulation, Output Voltage vs. Output Current**



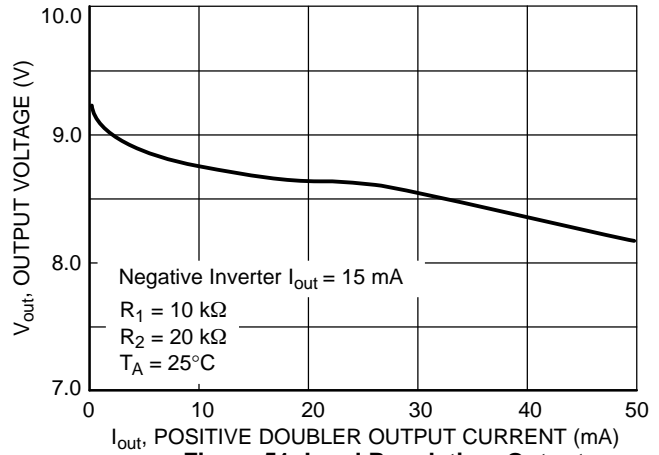
**Figure 49. Combination of a Closed Loop Negative Inverter with a Positive Output Voltage Doubler**

# MAX1720

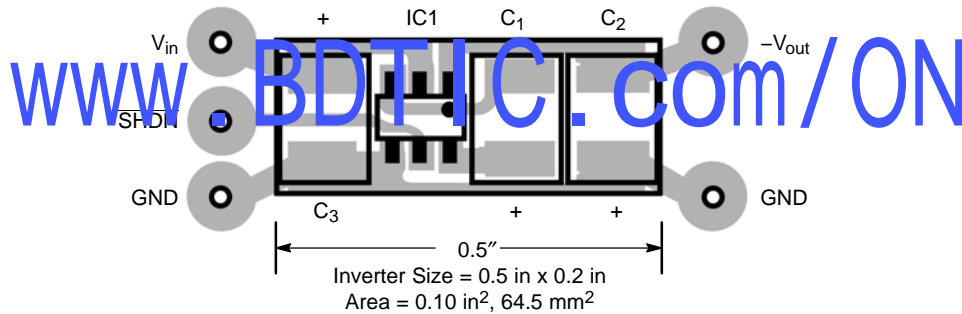
All of the previously shown converter circuits have only single outputs. Applications requiring multiple outputs can be constructed by incorporating combinations of the former circuits. The converter shown above combines Figures 26 and 32 to form a regulated negative output inverter with a non-regulated positive output doubler. The magnitude of  $-V_{out}$  is controlled by the resistor values and follows the relationship  $-V_{ref} (R_2/R_1 + 1)$ . Since the positive output is not within the feedback loop, its output voltage will increase as the negative output load increases. This cross regulation characteristic is shown in the upper portion of Figure 50. The dashed line is the open loop and the solid line is the closed loop configuration for the load regulation. The load regulation for the positive doubler with a constant load on the  $-V_{out}$  is shown in Figure 51.



**Figure 50. Load Regulation, Output Voltage vs. Output Current**



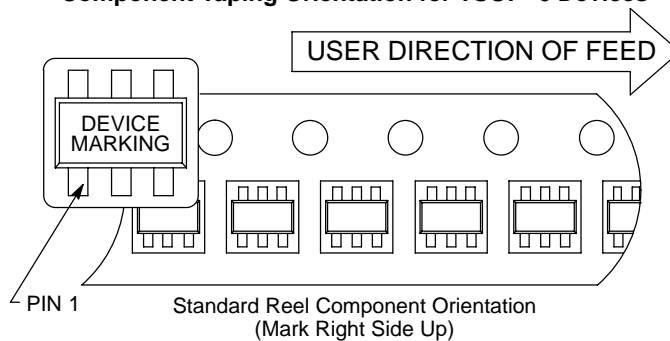
**Figure 51. Load Regulation, Output Voltage vs. Output Current**



**Figure 52. Inverter Circuit Board Layout, Top View Copper Side**

## TAPING FORM

### Component Taping Orientation for TSOP-6 Devices



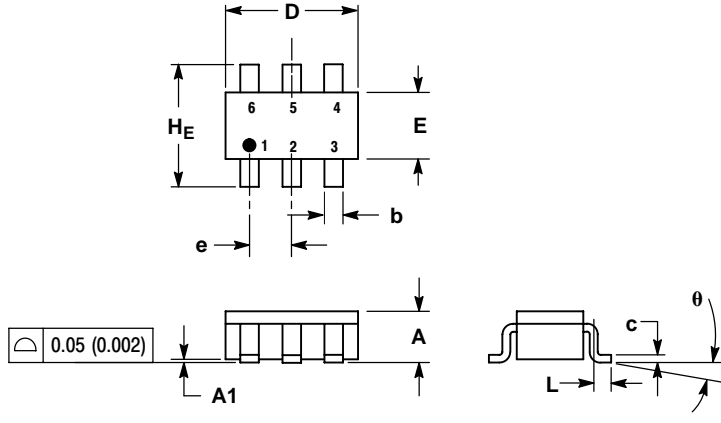
**Tape & Reel Specifications Table**

Package	Tape Width (W)	Pitch (P)	Part Per Full Reel	Diameter
TSOP-6	8 mm	4 mm	3000	7 inches

# MAX1720

## PACKAGE DIMENSIONS

TSOP-6  
CASE 318G-02  
ISSUE P

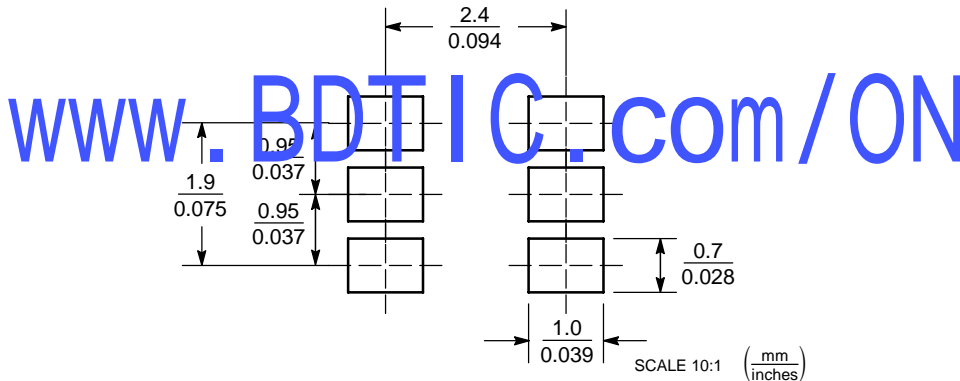


NOTES:

1. DIMENSIONING AND TOLERANCING PER ANSI Y14.5M, 1982.
2. CONTROLLING DIMENSION: MILLIMETER.
3. MAXIMUM LEAD THICKNESS INCLUDES LEAD FINISH THICKNESS. MINIMUM LEAD THICKNESS IS THE MINIMUM THICKNESS OF BASE MATERIAL.
4. DIMENSIONS A AND B DO NOT INCLUDE MOLD FLASH, PROTRUSIONS, OR GATE BURRS.

DIM	MILLIMETERS			INCHES		
	MIN	NOM	MAX	MIN	NOM	MAX
A	0.90	1.00	1.10	0.035	0.039	0.043
A1	0.01	0.06	0.10	0.001	0.002	0.004
b	0.25	0.38	0.50	0.010	0.014	0.020
c	0.10	0.18	0.26	0.004	0.007	0.010
D	2.90	3.00	3.10	0.114	0.118	0.122
E	1.30	1.50	1.70	0.051	0.059	0.067
e	0.85	0.95	1.05	0.034	0.037	0.041
L	0.20	0.40	0.60	0.008	0.016	0.024
HE	2.50	2.75	3.00	0.099	0.108	0.118
θ	0°	-	10°	0°	-	10°

### SOLDERING FOOTPRINT\*



\*For additional information on our Pb-Free strategy and soldering details, please download the ON Semiconductor Soldering and Mounting Techniques Reference Manual, SOLDERRM/D.

ON Semiconductor and are registered trademarks of Semiconductor Components Industries, LLC (SCILLC). SCILLC reserves the right to make changes without further notice to any products herein. SCILLC makes no warranty, representation or guarantee regarding the suitability of its products for any particular purpose, nor does SCILLC assume any liability arising out of the application or use of any product or circuit, and specifically disclaims any and all liability, including without limitation special, consequential or incidental damages. "Typical" parameters which may be provided in SCILLC data sheets and/or specifications can and do vary in different applications and actual performance may vary over time. All operating parameters, including "Typicals" must be validated for each customer application by customer's technical experts. SCILLC does not convey any license under its patent rights nor the rights of others. SCILLC products are not designed, intended, or authorized for use as components in systems intended for surgical implant into the body, or other applications intended to support or sustain life, or for any other application in which the failure of the SCILLC product could create a situation where personal injury or death may occur. Should Buyer purchase or use SCILLC products for any such unintended or unauthorized application, Buyer shall indemnify and hold SCILLC and its officers, employees, subsidiaries, affiliates, and distributors harmless against all claims, costs, damages, and expenses, and reasonable attorney fees arising out of, directly or indirectly, any claim of personal injury or death associated with such unintended or unauthorized use, even if such claim alleges that SCILLC was negligent regarding the design or manufacture of the part. SCILLC is an Equal Opportunity/Affirmative Action Employer. This literature is subject to all applicable copyright laws and is not for resale in any manner.

### PUBLICATION ORDERING INFORMATION

**LITERATURE FULFILLMENT:**  
Literature Distribution Center for ON Semiconductor  
P.O. Box 61312, Phoenix, Arizona 85062-1312 USA  
**Phone:** 480-829-7710 or 800-344-3860 Toll Free USA/Canada  
**Fax:** 480-829-7709 or 800-344-3867 Toll Free USA/Canada  
**Email:** orderlit@onsemi.com

**N. American Technical Support:** 800-282-9855 Toll Free USA/Canada  
**Japan:** ON Semiconductor, Japan Customer Focus Center  
2-9-1 Kamimeguro, Meguro-ku, Tokyo, Japan 153-0051  
**Phone:** 81-3-5773-3850

**ON Semiconductor Website:** <http://onsemi.com>  
**Order Literature:** <http://www.onsemi.com/litorder>

For additional information, please contact your local Sales Representative.