

# PM8800A: integrated PoE power devices interface and PWM controller

The integrated solution for standard and high-power PoE power devices



The PM8800A is the first of a family of devices targeting standard PoE and higher power power devices.

The PM8800A combines a standard IEEE 802.3af interface, a current-mode PWM controller and a best-in-class hot-swap MOSFET in a single package. It also integrates the signature resistor, so minimizing the external component count.

Designed in a 100 V capable technology, the PM8800A features programmable inrush and DC current up to 800 mA (twice today's PoE limit) for applications requiring power greater than 15 W.

Housed in a HTSSOP16 package for better thermal performance, the PM8800A also allows simple and robust design of power devices with power from auxiliary sources.

## Features

- IEEE 802.3af compliant power device interface
- Works with power supplied from Ethernet LAN cables or from local auxiliary sources
- Integrated 100 V, 0.5  $\Omega$ , 800 mA hot-swap MOSFET
- Integrated signature resistor
- Programmable in-rush current limit
- Power good indication
- Programmable DC current limit up to 800 mA
- High-voltage start-up bias regulator
- Thermal shutdown protection
- Current-mode pulse width modulator
- Integrated error amplifier and voltage reference
- Programmable oscillator frequency
- 80 % maximum duty cycle with internal slope compensation
- Supports both Isolated and non-isolated applications

## Main applications

- VoIP phones
- WLAN access points
- Security cameras
- PoE power device appliances
- High power (>12.95 W) power devices

The PM8800A integrates a standard power-over-ethernet (PoE) interface and a current-mode PWM controller to simplify the design of the power supply sections of all power devices (PD).

The PoE interface incorporates all the functions required by the IEEE 802.3af including detection, classification, under-voltage lockout (UVLO) and inrush current limitation.

The PM8800A specifically targets PDs with extended power requirements with respect to the limit imposed by the 802.3af standard, embedding a hot-swap MOSFET capable of sustaining twice the current of the 802.3af

standard with a programmable DC current limit.

The integrated switching regulator of the PM8800A has been designed to work with power either from the Ethernet cable connection or from an external power source such as an AC adapter.

The DC/DC section of the PM8800A features a programmable oscillator frequency, soft-start, slope compensation and embeds a voltage output error amplifier allowing use in both isolated and non-isolated configurations the PM8800A comes in an HTSSOP16.

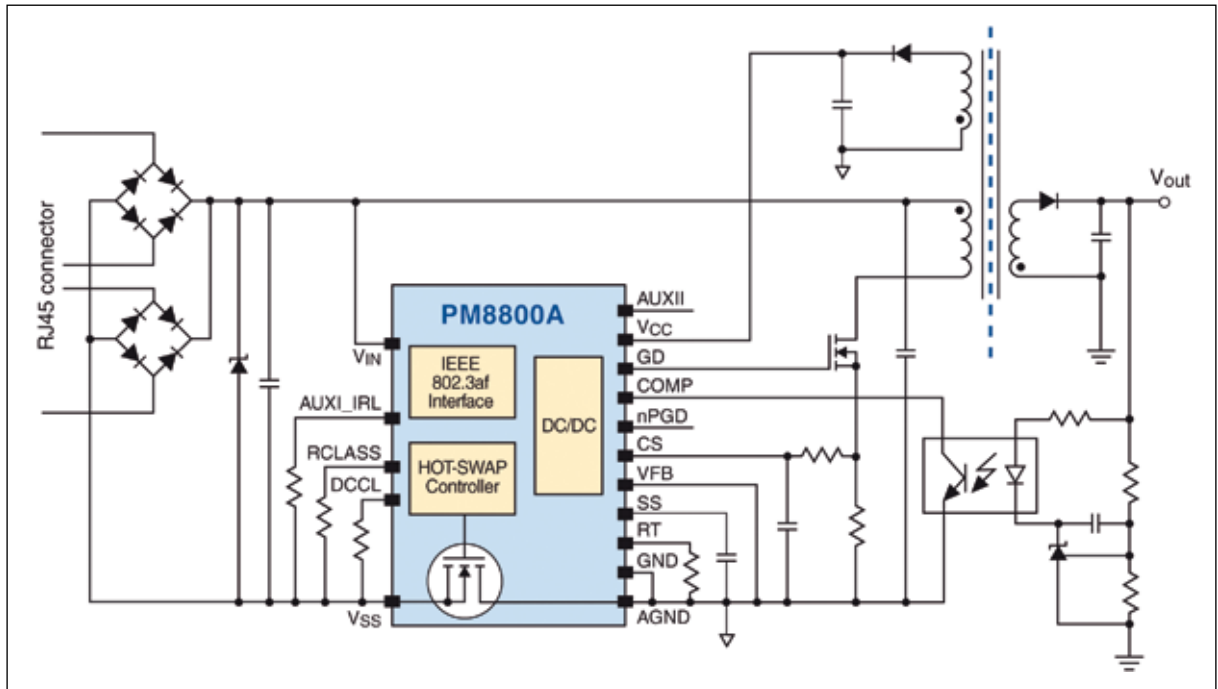

PM8800A typical application schematic for isolated configuration



© STMicroelectronics - December 2007 - Printed in Italy - All rights reserved

The STMicroelectronics corporate logo is a registered trademark of the STMicroelectronics group of companies. All other names are the property of their respective owners.

For selected STMicroelectronics sales offices fax:

China +86 21 34054689; France +33 1 55489569; Germany +49 89 4605454; Italy +39 02 8250449; Japan +81 3 57838216; Singapore +65 64815124; Sweden +46 8 58774411; Switzerland +41 22 9292900; United Kingdom and Eire +44 1628 890391; USA+1 781 861 2678

Full product information at [www.st.com](http://www.st.com)